

# London Electronics Limited

Thorncote Green, Near Hatch, Sandy, Bedfordshire SG19 1PU  
Tel +44(0)1767 626444 Fax +44(0)1767 626446  
www.london-electronics.com help@london-electronics.com

## Panel mounting remote temperature display/controller

# INT-T

## **Connection details, scaling and general information**

Digital Scaling and calibration  
User friendly, time-saving design  
Fast installation and commissioning

# *Table of Contents*

- 1)       Introductory Notes
- 2)       Very Important Warnings
- 3)       Equipment Specifications
- 4)       Connection Details
- 5)       Adjustments + Calibration
- 6)       Special Features
- 7)       Alarm & Analogue O/P configuration
- 8)       Serial Data Output Notes
- 9)       Record of Revisions/Changes
- 10)      Declaration of Conformity

# *Important introductory notes*

Thank you for choosing to use a London Electronics Ltd. product. We hope that you will be entirely satisfied with your purchase, and welcome any comments you may have which will help us to improve the ease of use, clarity of this manual, etc. for future shipments.

We invite you to write to us, free of charge, if posted in the United Kingdom, to:-

**London Electronics Ltd.  
Customer Services Department  
FREEPOST SG334  
SHEFFORD  
Bedfordshire SG17 5BR**

Alternatively you may send us a fax on **01462-850968** (international code +44)  
Or, telephone us on **01462-850967** (international code +44)

Or, send us an E-Mail to **help@london-electronics.com**

To enable us to provide a swift and accurate service, please be sure to provide the following information :-

- 1) Full Model Number , including all options fitted.
- 2) Serial Number
- 3) DETAILED description of your difficulties, suggestions etc.
- 4) Input Range and Display range

This product is covered by a 2 year warranty, during which period we will put right or replace any meter found to be faulty through bad workmanship or materials. This warranty does not cover damage caused by misuse or accident.

**IMPORTANT** If the meter is a vital component in your process, you may wish to consider the purchase of a spare to cover the possible eventuality of a failure or accident, as we cannot guarantee instant repair or replacement.

We are constantly striving to improve our products and services, and as a result, changes to instruments do occur. Please ensure that this manual is kept safely for future reference, as future manuals, covering revised designs may no longer describe your product accurately.

We believe these instructions to be accurate, and the product to be competently designed and manufactured. We do not make any claims as to the suitability of this product for any particular application. The choice of product and responsibility for the choice lies with the User.

# VERY IMPORTANT WARNINGS



**You should carefully read all warnings and commence installation ONLY when you are satisfied that all warnings are adequately covered.**



! Connections to this equipment shall be carried out in accordance with current IEE regulations, and all wiring shall be separated in accordance with IEC1010

Notes:

! Power supplies to this equipment must be anti-surge fused at 125mA for 230V supply, 250mA for 110V supply or 1A for DC supplies in the range 11-30VDC

Notes:

! Before installation, check that model number and supply voltage suit your application

Notes:

! Lethal voltages may be present on the circuit board. Do not touch any circuitry when power is applied.

Notes:

! This product is designed for Installation class II service

Notes:

! This product is designed for use in Pollution-Degree 2 environments

Notes:

! Use an insulated screwdriver when adjusting potentiometers and do not touch any circuitry

Notes:

! Replace front cover when meter is unattended

Notes:

! All adjustments to jumper settings or terminations must be made with power removed

Notes:

! Ensure all screw terminals are tight before applying power.

Notes:

***Safety First .....Don't make assumptions..... Always double check.  
If in doubt, ask someone who is QUALIFIED to assist you in the subject.***

# Equipment Specifications

## Mechanical:

<b>Bezel size</b>	48mm high by 96 mm wide (1/8 DIN)
<b>Panel Cutout</b>	45 mm high by 92 mm wide
<b>Case Depth</b>	120 mm including connectors
<b>Weight</b>	300 grammes
<b>Case Material</b>	Black polycarbonate
<b>Connectors</b>	Detachable Screw Terminal connectors

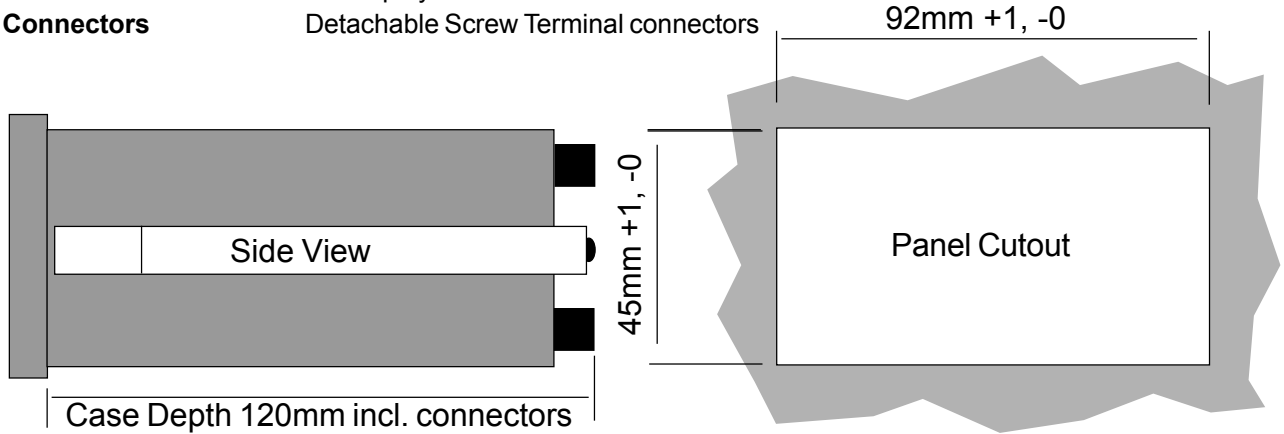

## Electrical:

<b>Power</b>	95-265 VAC or 11-30 VDC optional
<b>Burden</b>	8VA maximum

## Input Signals:

INTUITIVE-T	T/C's type	J,	K,	T,	N,	R,	S,	Pt100	DIN and ANSI
<b>Accuracy (+/- Deg. C)</b>		0.5	0.6	0.3	1.0	1.0	1.0	0.2	0.2
<b>Max. Resolution Deg. C</b>		0.1	0.1	0.1	0.1	0.1	0.1	0.1	0.1
<b>Input Resistance</b>	>10 Megohms. PT100's have 300uA excitation current								
<b>Span tempco</b>	50ppm/Degree Celsius								
<b>Zero Tempco</b>	0.05DegC/C for thermocouples 20ppm/C for PT100								
<b>A/D technique</b>	Dual slope integration								
<b>A/D conversion rate</b>	10 conversions per second (for peak detection & analogue O/P)								
<b>Display update rate</b>	2 readings per second								

<b>ANALOGUE O/P</b>	0-10VDC	4-20mA	+/-5VDC
<b>Drive capacity</b>	>1K Ohms	<500 Ohms	>1 K Ohms
<b>Isolation</b>	250 VAC Optically isolated		
<b>Linearity</b>	+/-0.02% of range, accuracy 0.1% of range		
<b>Resolution</b>	12 bits		

<b>ALARM O/P</b>	4 alarms SPST rated 5 Amperes at 250 VAC, resistive load
------------------	--

<b>ASCII O/P</b>	RS232 or RS422 transmission of reading. 1200 baud
<b>Isolation</b>	250 VAC optically isolated

## ORDERING GUIDE

Typical part number INTUITIVE-T-0-SP-422

Family	Basic Meter type	Analogue O/P	Setpoints	Data Output
<b>INTUITIVE</b>	<b>T =Temperature</b>	<b>0 =none</b> <b>AN =fitted</b>	<b>0 =none</b> <b>AL2 =2</b> <b>AL4 =4</b>	<b>0 =none</b> <b>232 =RS232</b> <b>422 =RS422</b>

# Connections

**Connector Specifications :-** [VDE Rated Voltage, group B insulation VAC = 380]-[VDE Rated Current = 8 Amperes.]  
 [Vibration Immunity per VDE0611 <10g]-[Rated Number of mating cycles <100]-[Screw Clamp material/plating Steel/ZnCc]  
 [Contact Spring material/plating CuSN/gal SnPb]-[Plug-in force, per pole is from 3 to 6 Newtons]-[Disconnect force per pole is from 4 to 7 Newtons]-[Screw clamp tightening torque recommended 0.5Nm]-[Solid wire csa between 0.13 to 1.5mm<sup>2</sup>] [Multistrand wire csa from 0.5 to 1.5mm<sup>2</sup>]-[AWG conductor range from 22 to 16]-[Gauge to DIN/EN50027 Size A1]

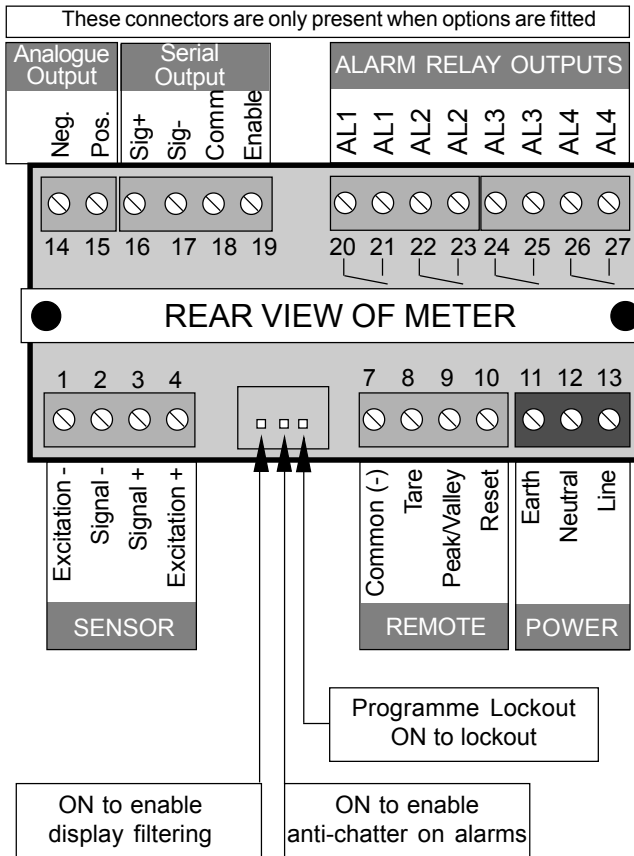

## Serial Output Connection Notes

### 1) RS232 option type

The RS232 data appears on terminal 16  
 Data common on terminal 18  
 RTS on terminal 19  
 Pullup on terminal 17

To produce a continuous stream of data, connect terminals 17 and 19 together, or, for one-shot transmissions, apply a single pulse of 5V level to terminal 19.

### 2) RS422 option type

The RS422 data appears on terminals 16 and 17. Common is on terminal 18.

To produce a continuous stream of data, connect terminals 18 and 19 together, or, for one-shot transmissions, apply a single pulse of 0V level to terminal 19

## INPUT CONNECTION EXAMPLES

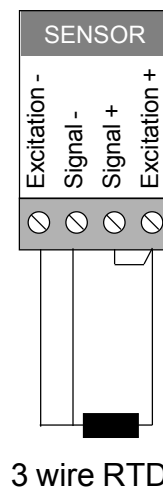
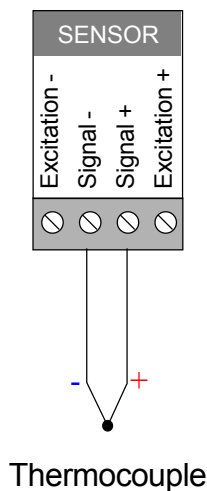

See [http://www.london-electronics.com/tc\\_iec584\\_3.php](http://www.london-electronics.com/tc_iec584_3.php) for European thermocouple colour codes  
 See [http://www.london-electronics.com/tc\\_ansimc96\\_1.php](http://www.london-electronics.com/tc_ansimc96_1.php) for American thermocouple colour codes

# Adjustments And Calibration

The selection of input sensor type and display resolution may selected via the front panel.

To enter the setup sequence, the display must have a sensor connected.

Press '**SPAN**' to enter the setup. The display will show sensor type.

To select a different sensor type, press **SPAN/d.p** repeatedly. The display will show.....

<b>tcJ</b>	<b>tcK</b>	<b>tct</b>	<b>tcn</b>	<b>tcr</b>	<b>tcS</b>	<b>rt8</b>	<b>rt9</b>
type J	type K	Type T	type N	type R	type S	PT100 DIN	PT100 ANSI

To select a different resolution or Degrees F or Degrees C, press '**OUTPUT**' whilst the chosen sensor type is displayed . Display shows..

.°C = degrees C 0.1 degree resolution

°C = degrees C 1 degree resolution

.°F = degrees F 0.1 degree resolution

°F = degrees F 1 degree resolution

After completing your selection, press '**OK**'.

To correct for any zero offset, apply a known input value, press the 'ZERO' button for >3 seconds and at the same time press either the up-arrow or down-arrow to increase or decrease the reading to the desired value. After correcting zero offset, press '**OK**'

## ALARM ADJUSTMENT

See p. 7 for board configuration

Pressing the ALARMS button momentarily will allow you to view the current alarm settings (each press will illuminate in turn AL1, AL2, AL3 and AL4 annunciators) To change the settings, keep the button held for 3 seconds which will cause the value have one digit brighter than the others. This may be changed in value using the UP/DOWN buttons, and the digit can be selected using the DIGIT SELECT pushbutton. The alarm action is determined by the left-hand character. This will show an 'H' for HIGH alarm action, an 'L' for LOW alarm action, or a 'o' for NO alarm action. This character may be amended using the UP/DOWN buttons. Press OK when correctly set.

## ANALOGUE O/P ADJUSTMENT

See p. 7 for board configuration

- 1) Press 'OUTPUT' button for 3 seconds
- 2) 0% O/P LED should flash
- 3) Set the display to the reading value you wish to generate 0% Output by using DIGIT SELECT & UP/DOWN
- 4) When display correctly set, press OK
- 5) Now the 100% O/P LED should flash
- 6) Set the display to the reading value you wish to generate 100% Output by using DIGIT SELECT & UP/DOWN
- 7) When display correctly set, press OK

# Special Features

## Peak and Valley detection

The meter samples the sensor 10 times per second and compares the sample to previous peaks or troughs and updates the peak or trough memory if required with the new value.

There are 2 ways of viewing the stored peaks, either by the front panel pushbuttons or by external contact closure.

Peak is annunciated on the display by the left hand digit's upper bar illuminating (identified as 'Max.' on the front panel)

Valley is annunciated on the display by the left hand digit's lower bar illuminating (identified as 'Min.' on the front panel). The selection of actual reading, peak and valley is sequential.

### Front panel key viewing of Peak/Valley

- 1) Link terminal 7 to terminal 9
- 2) Fit programme lockout jumper
- 3) Press UP arrow key for peak, valley, normal

### Remote contact closure viewing of Peak/Valley

- 1) Connect a normally-open contact closure switch between terminals 7 and 9
- 2) Fit programme lockout jumper

## Reset Command

The reset command clears any stored peak or valley data and may be accessed either from the front panel or by external contact closure command.

### Front Panel key reset command

- 1) Link terminal 7 to terminal 10
- 2) Fit programme lockout jumper
- 3) Press Down Arrow key to reset display

### Remote contact closure resetting

- 1) Connect a normally-open contact closure switch between terminals 7 and 10
- 2) Fit programme lockout jumper



# Alarm Board Configuration

For failsafe operation (where contacts open on alarm or when power is lost to the meter) set the jumpers for OPEN CONTACTS and DE-ENERGISE on alarm.

Using the ALARM button on the Fascia, you may perform the following actions:-

## VIEW Setpoint values and alarm action only

Press ALARM key briefly. The display will show AL1 setpoint and action (H= High Alarm, L=Low Alarm, o=No Alarm). Each press of the key will take you on to the next alarm channel, see the Alarm annunciators for channel identification.

## VIEW & CHANGE Setpoint Values and alarm action

Press ALARM key for more than 3 seconds. AL1 annunciator will show, and you will see one digit is brighter than the others.

Use DIGIT key to select a digit and the UP or DOWN key to amend a digit's value. The left hand digit sets the alarm action as HIGH, LOW or off, with an H,L or o , respectively.

When all digits are set as desired, press OK.

## VIEW & CHANGE Hysteresis Values

After setting alarm value, display will show HYXXXX Where HY means hysteresis and XXXX is the amount of hysteresis. Set and store value as for alarm setpoint.

To gain access to the alarm board, first remove power from meter, including any power which might be present on the alarm output circuitry.

Look on the top and bottom surfaces of the case, near the rear. You will see two small screws, one on each surface. Remove both screws. Now, clip off the front bezel and slide the meter assembly carefully out via the front of the case.

To re-assemble, reverse this procedure.

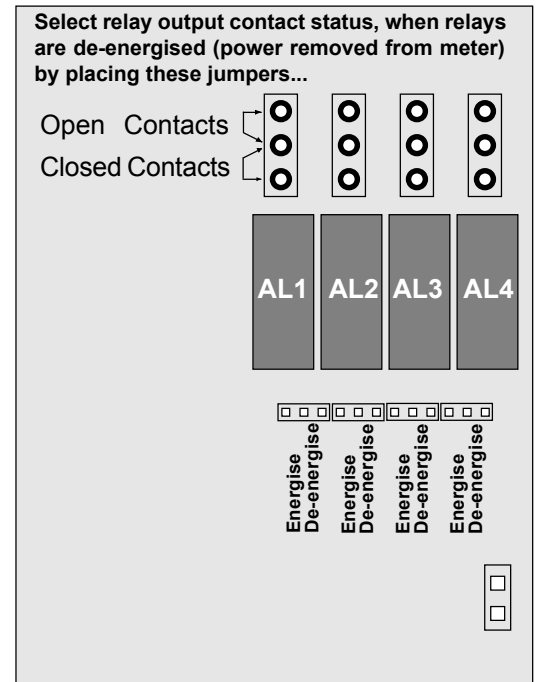

# Analogue O/P Configuration

The analogue output board is factory configured for either -5 to +5V, 0-10V or 4-20mA and will require no adjustment other than setting the reading values to generate 0% and 100% of output, using the front panel pushbuttons.

However, to change a range, for example from 0-10V to 4-20mA, the zero and span potentiometers must be adjusted to obtain the correct output levels at 0% and 100%.

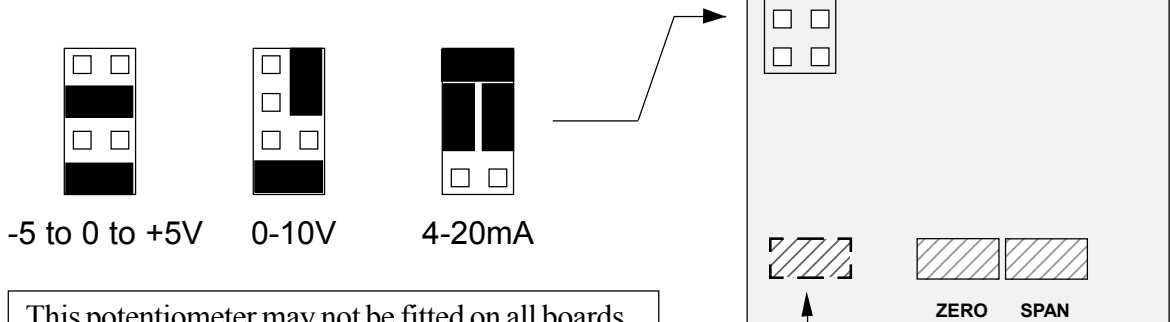

This potentiometer may not be fitted on all boards. It is *only* to be adjusted in the factory.

# Serial Communications Output

Depending on the option installed, the Intuitive will provide either an RS232 or an RS422 ASCII output at a baud rate of 1200 representing the meter's displayed value. It is possible to obtain a continuous transmission of readings, or a single transmission on demand.

RS232 O/P on terminal 16 (data+) and terminal 18(common)

RS422 O/P on terminals 16 & 17(Data + and -) and 18 (common)

## String Format:

The string is presented as ASCII coded numerals, with embedded decimal point position if one has been set on the display, with a preceding - sign if the display is negative, with leading zero blanking, followed by a Carriage Return and a Line Feed.

So, for a displayed value of....

12345      the string will be <space><space><1><2><3><4><5><CR><LF>

-15.0      the string will be <space><space><-><1><5><.><0><CR><LF>

## Commands:

The data output port is enabled by way of a hardware connection to the ENABLE terminal.

For RS232, the ENABLE port must be held high at a 5V level for as long as serial data output is required, or, if only one string of data is needed, the ENABLE line must be held high until such time as the transmission commences, after which it may be taken low again. The Sig- connection on terminal 17 may be used to provide the 5V level if an external source is not available

For RS422, the ENABLE port operates in reverse, requiring to be held low to enable transmission.

If remote display is required, the Model SER-06 is an ideal choice, being a 1/8 DIN meter directly compatible with the INTUITIVE's output format.

Alternatively, we manufacture a range of Large Format remote displays having digit heights of 57mm, 102mm, 144mm, 200mm and 280mm. Ask us about the 1700 Series and the Grand Intuitive Series.

# Record of Revisions/Changes

- 28 April 1999 Page 4-Noted Factory-Only jumper  
Page 6 -Removed auto-zero text
- 10 May 1999 Rev. 1.1 software released.  
Software bug corrected, which caused corruption if analogue O/P adjusted whilst in RTD input selection. Another bug removed which caused occasional corruption of memory, with power supply interruption.  
Page 4 - Jumper position and identification amended.  
Page 9 - Calibration method modified and zero offset adjustment included
- 10 October 2001 Page 7 - Analogue O/P board potentiometer added
- 31 July 2003 back page - Declaration of Conformity amended
- 7 January 2005 Changed connection detail to remove 4 wire connection.

# Declaration of Conformity

Declaration Reference : INTUITIVE  
Issue Date : 9 October 1998 revised 31 July 2003  
Products Covered : INTUITIVE series  
Title : DOC-INTUITIVE

This is to confirm that the Product covered by this declaration have been designed and manufactured to meet the limits of the following EMC Standard :

EN61326-1:1997

and has been designed to meet the applicable sections of the following safety standards

EN61010-1:2001

## Conditions

The meters are permitted a worst case error of 1% of A/D range during electro-magnetic disturbance, and must recover automatically when disturbance ceases without the need for human intervention, such as resetting, power-down etc.

The meters covered by this certificate must be installed as follows :-

Signal cabling shall be routed separately to power carrying cabling (includes relay output wiring)

All signal cabling shall be screened. The screen shall only be terminated to the power earth terminal.

Declared as true and correct, for and on behalf of London Electronics Ltd.