

London Electronics Limited

Thorncote Road, Near Sandy, Bedfordshire SG19 1PU
Tel +44(0)1767 626444 Fax +44(0)1767 626446
www.london-electronics.com help@london-electronics.com

Panel mounting process bargraph / controller

BAR-A and BAR-X

Connection details, scaling and general information

Digital Scaling and calibration
User friendly, time-saving design
Fast installation and commissioning

This manual is for software Versions BARX1.0

Document Ref:pm65\manuals\Bars\BARX_new_ver0.p65

Dated: 30 June 2009

Rev. 2

Notes

Keep a note of your settings here.

Some time in the future, you or a colleague may need to recalibrate or replace this meter. We suggest you write down all your settings now to avoid panic and confusion in a crisis.

Meter Serial number

Full Model number

Input signal range (for example 4-20mA)

Display range (for example 0 to 100 %)

If you change any switch settings, mark your changes on the page in this manual which describes that switch.

What does the model number tell you? Use this table to find out...

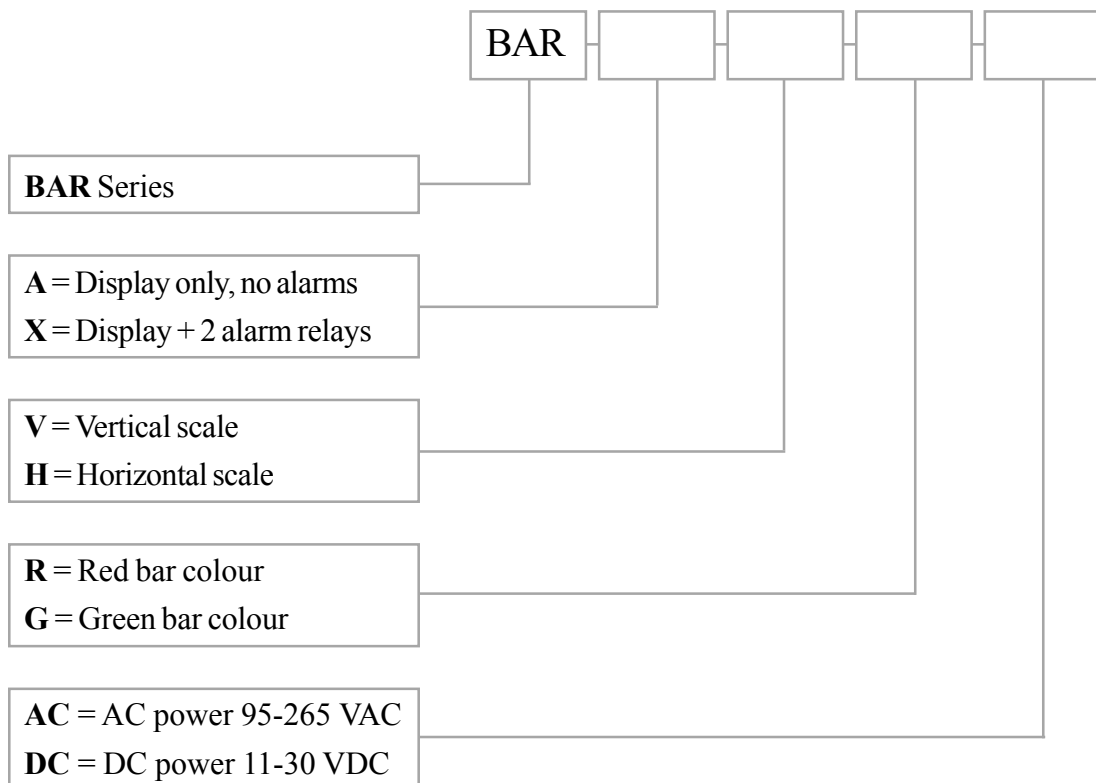

Alphabetic Index

Warnings - Read First !.....	1
Alarm connections.....	8
Alarm setting.....	16,17,18
Bar mode.....	3,7
Bezel - how to remove.....	6
Block diagram.....	5
Calibration method selection.....	7
Calibration - Factory preset ranges.....	11
Calibration - your own ranges.....	14,15
Connections.....	8
Declaration of Conformity.....	24
Display response speed selection.....	7
Dot mode.....	3,7
Excitation voltage.....	5,8,10
Front Panel controls.....	4
General Description.....	3
Getting Started.....	9
Hysteresis/Pump Control.....	18
Introduction.....	2
Input connection examples.....	10
Latching of Alarms.....	18
Lockout switch.....	5,8,11,14,15,16
Model number description.....	ii
Notes pages - for you to use.....	i,23
Peak reading memory.....	19
RESET button.....	20
Revision record.....	22
Scale sheets.....	12
Span setting.....	15
Specifications.....	21
Switches	4,5,7
Units-of-measure label.....	12
Valley reading memory.....	19
Warnings	1
Zero setting.....	14

Important Warnings



Carefully read all warnings and ONLY install the meter when you are sure that you have properly covered each point.

- * Connect the meter according to current IEE regulations and separate all wiring according to IEC1010.
- * Power supplies to this equipment must have anti-surge (T) fuses at 125mA for 230V supply, 250mA for 110V supply or 1A for DC supplies in the range 11-30VDC.
- * Check that the model number and supply voltage suit your application before you install the meter.
- * Don't touch any circuitry after you have connected the meter, because there may be lethal voltages on the circuit board.
- * We designed this meter for Installation class II service only. This means it has exposed electrical and power terminals, so you must install it in an enclosure to protect users from electric shock.
- * We designed this meter for Pollution-Degree 2 environments only. This means you must install it in a clean, dry environment, unless it has extra protection from a splashproof cover, such as our SPC4
- * Only adjust on-board switches or connections with the power turned off
- * Make sure all screw terminals are tight before you switch the meter on.
- * Only clean the meter with a soft damp cloth. Only lightly dampen with water. Do not use any other solvents.

Safety FirstDon't assume anything..... Always double check. If in doubt, ask someone who is QUALIFIED to help you in the subject.

Introduction

Please contact us if you need help, if you have a complaint, or if you have suggestions to help us improve our products or services for you.

If you contact us about a product you already have, please tell us the full model number and serial number, so that we can give you accurate and fast help.

This product has a 2 year warranty. We will put right or replace any meter which is faulty because of bad workmanship or materials. This warranty does not cover damage caused by misuse or accident.

IMPORTANT

If this equipment is important to your process, you may want to buy a spare to cover possible failure or accidental damage in the future.

This is because at some times, for example during our factory shutdown periods, you may have to wait several weeks for an equivalent replacement. Or, we may have no stock at the time you urgently need it.

You may also need to pay extra carriage charges if you want a fast, guaranteed courier service. Warranty repairs or replacements are normally returned with a standard courier service.

We do not offer any compensation for losses caused by failure of this instrument.

If you do not agree with these conditions, please return this item now, in unused, clean condition, in its original packaging and we will refund the purchase price, excluding any carriage paid.

We thought you'd prefer to know about possible delays and extra charges now, rather than during a panic.

We always try to improve our products and services, so these may change over time. You should keep this manual safely, because future manuals, for new designs, may not describe this product accurately.

We believe these instructions are accurate, and that we have competently designed and manufactured the product, but please let us know if you find any errors.

General Description

The BAR-A and BAR-X bargraph indicators give you a simple, clear display to show you the approximate value of a physical variable.

They have an industry-standard 1/8 DIN bezel size, which is 48mm x 96mm.

Popular reasons why people use the BAR-A and BAR-X include ...

- * Display the level of liquid in a container :-
You can quickly see how full or empty the container is.
- * Show the temperature in a process :-
Gives a user-friendly format, similar to a glass thermometer
- * Show the relative position of an object :-
You can mount the bargraph vertically or horizontally, to show Up/Down, Left/Right, Front/Back measurements, etc. This is useful in tasks where you want to position an object accurately.

Features

Can accept most process signals such as 4-20mA, 0-10V , 1-5V etc.

You can power 2 wire transmitters with the standard 24V excitation supply.

You can set the display as a moving dot or accumulating bar format to best suit your application. You can also choose slow or fast response speed.

Position displays normally have moving dot.

Tank level and temperature displays normally have accumulating bar format.

You can order your bargraph with red or green LED display colour



Moving dot format - normally horizontal



Accumulating bar format normally vertical

The BAR-X has 2 alarm relays, which you can use to control simple processes. You can set each alarm to activate when the measurement goes above or below a setpoint. You can set the alarm level anywhere within the measurement range.

The front panel

This page shows you the general layout of the front panel. It doesn't describe any of the functions in detail, because each function has its own page in this manual.

We normally fit the measurement type label and scale labels for you. You'll need to tell us if you want to mount your bargraph vertically (as you see here) or horizontally, so that we can fit the labels correctly.

You can order red or green display colour.

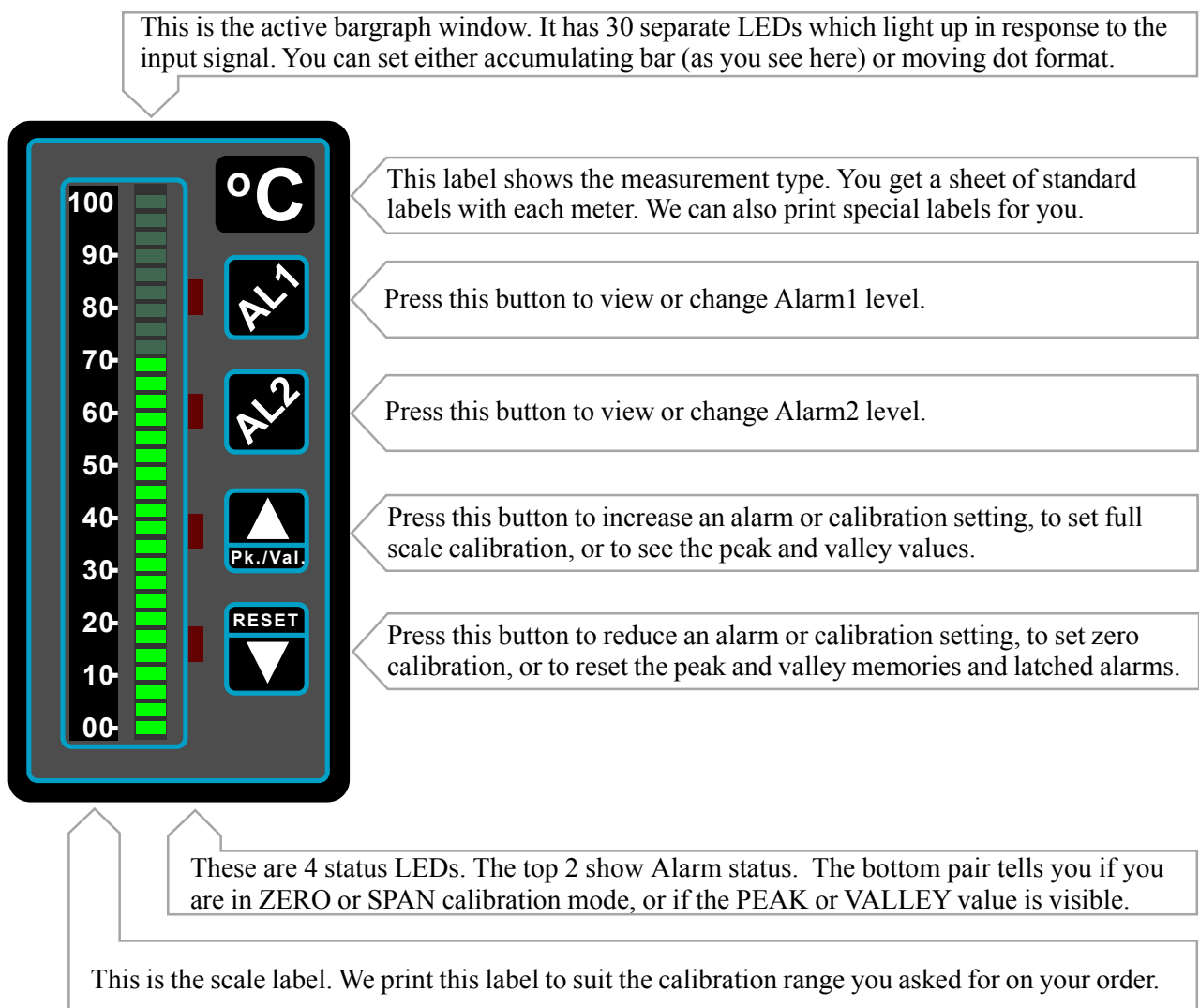

Control Type	4 button switches behind a flexible overlay
Button Functions	Depends on mode (whether locked or in setup mode)
Options	You can tell us which measurement type (°C, bar, kg etc.) you want, and what range the measurement will cover. You can download a wide selection of scale sheets from http://www.london-electronics.com/barscales.htm

Functional Block-diagram

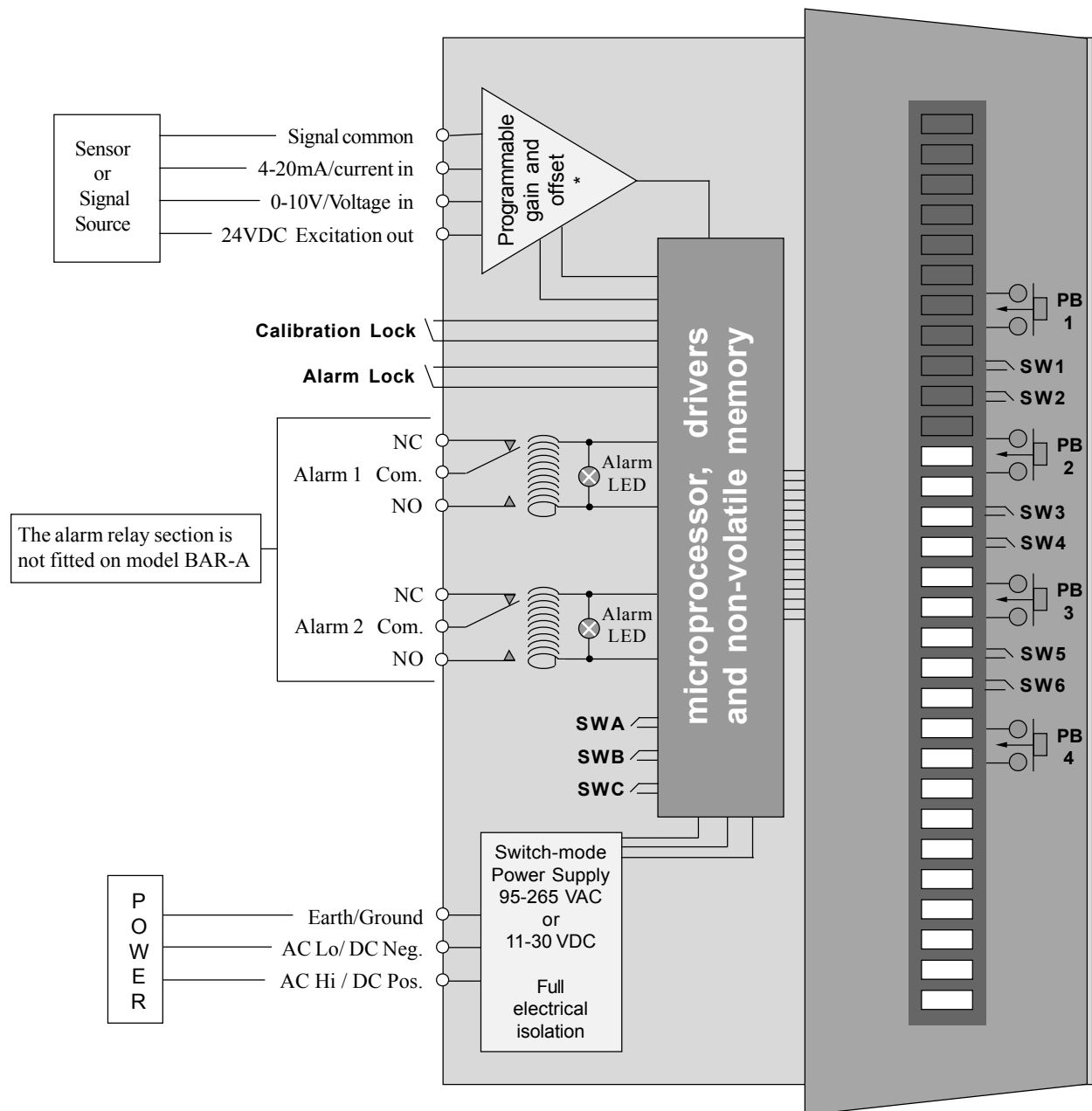

All connectors are detachable screw terminal types.

* Gain and offset are software variables which you set when you calibrate your display.

PB1 to PB4

Front panel pushbuttons which allow you to set scaling and alarm points

SW1 to SW6

Front panel switches which set the alarm type, display format, calibration mode and display update speed.

Alarm Lock and Calibration Lock

Switches on the back of the display, which lock the calibration & alarm settings.
Settings are saved in non-volatile memory.

SWA, SWB and SWC Solder switches. These are factory set.

How to remove the front bezel

You'll need to remove the front bezel if you want to check or change any of the configuration switch positions, and if you want to change the scale sheet.

You DO NOT need to remove the bezel if you want to recalibrate the display or if you want to change the alarm setpoints.

Before you remove the bezel, isolate power from the meter !

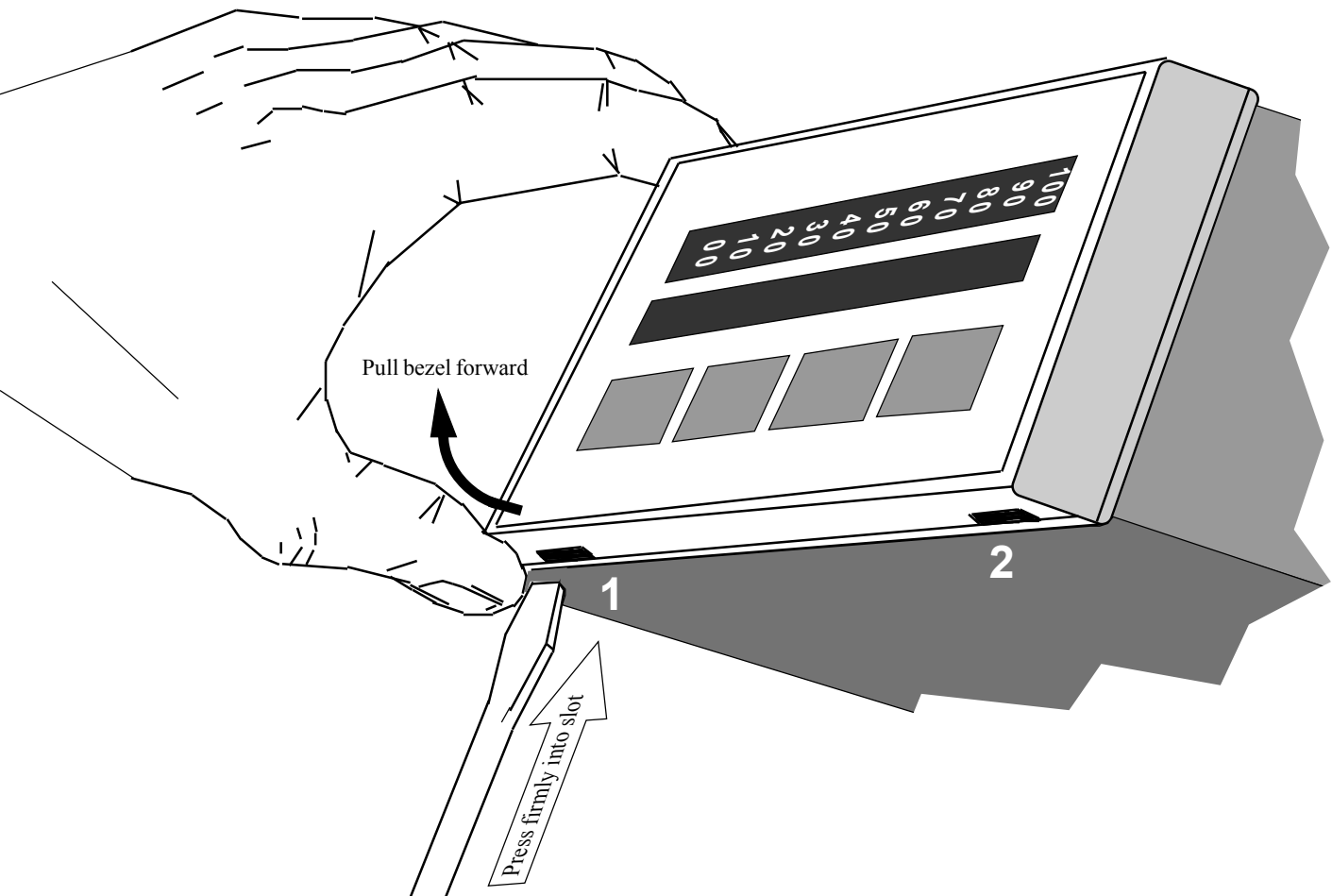

1. Push a terminal screwdriver firmly into the first slot, as you see here. When you press the screwdriver into this slot, pull the bezel forward. It should unclip.
2. Repeat for the second slot. The bezel should come off completely.
3. Store the bezel safely so that it doesn't get lost or damaged.

Replace the bezel BEFORE you apply power to the meter.

Switches behind the front bezel

When you've removed the front bezel, you'll see 3 pairs of DIP switches which set some of the meter's functions .

The factory default settings have a solid arrow →

If you change any switch settings, use a red pen to colour the arrows below, next to the switch setting you chose.

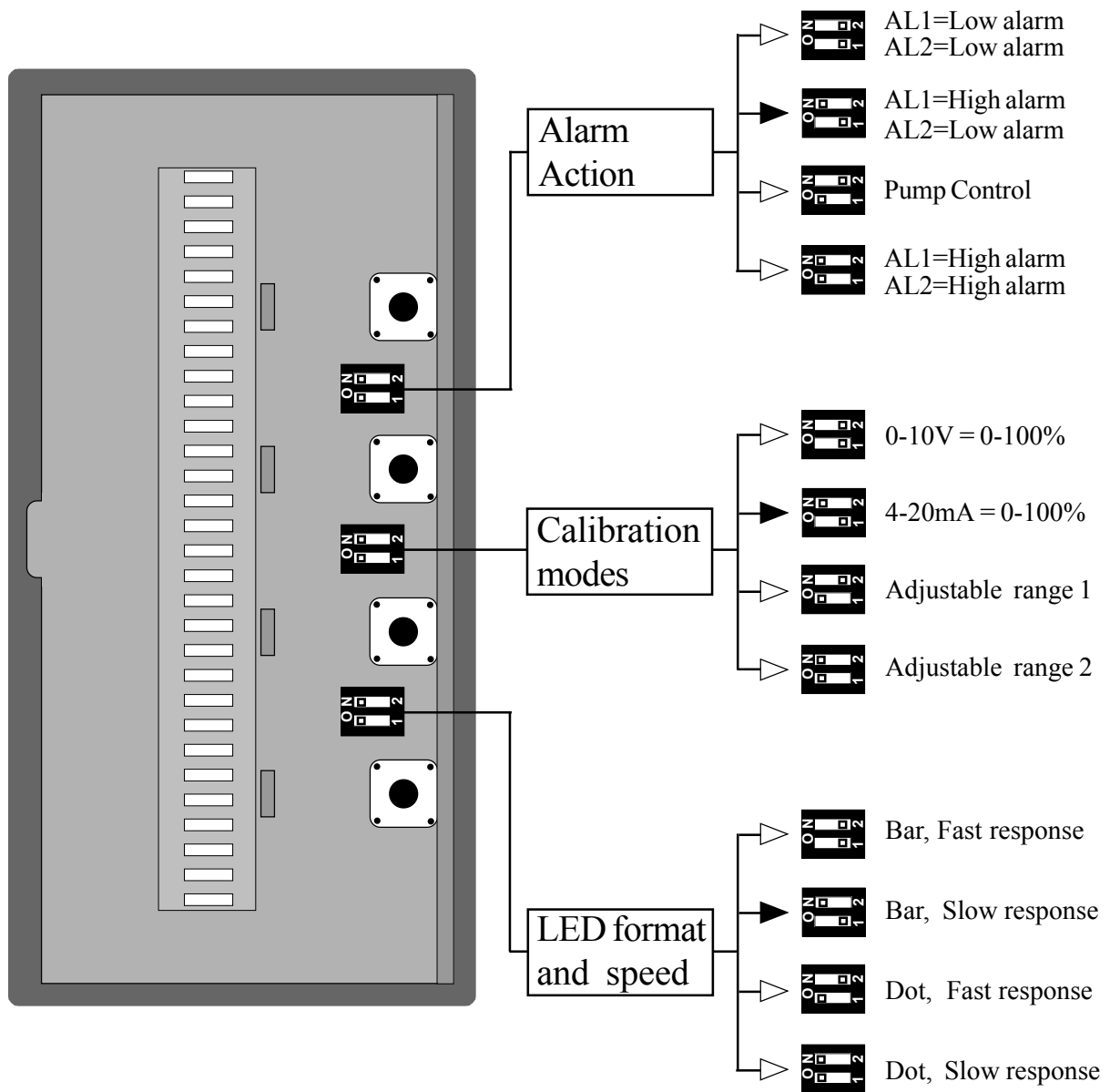

Replace the bezel BEFORE you apply power to the meter.

Connections and rear switches

Use screened cable for the input signal and connect the screen to power earth at the meter end of the cable only. Keep the signal cable away from the power and alarm cables, because these could carry electrical noise which may interfere with your measurements. Case depth is 125mm. The cables don't add any extra depth.

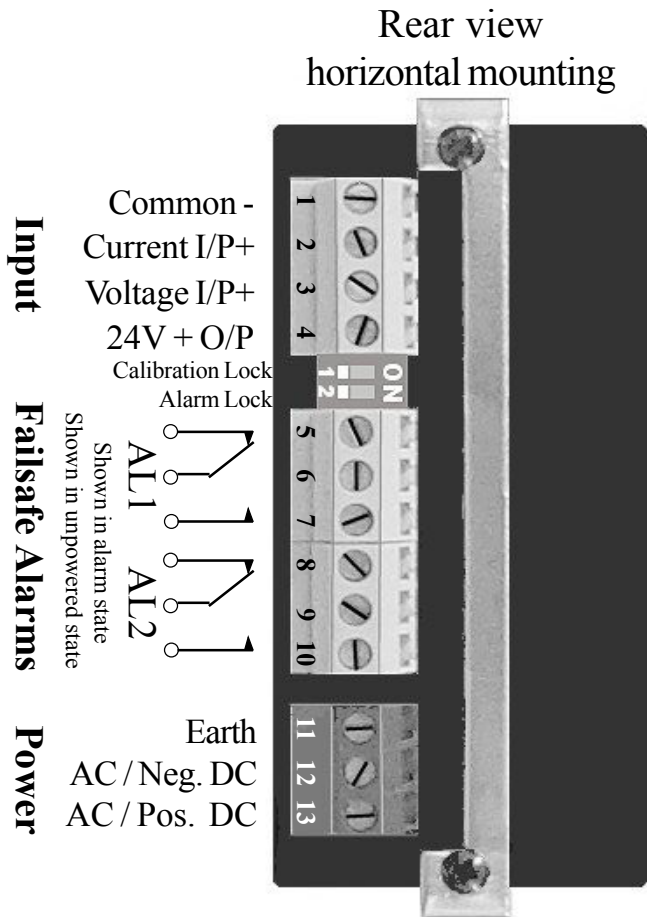

Detachable screw terminal connectors allow rapid installation and servicing.

Use multistrand insulated wire, with ferrules to DIN46228/1.

You can use stripped wire with cross sectional area from 0.5 to 2.5mm².

Strip back the insulation 7mm.

You'll find the terminal numbers on the rating label, not on the connectors .

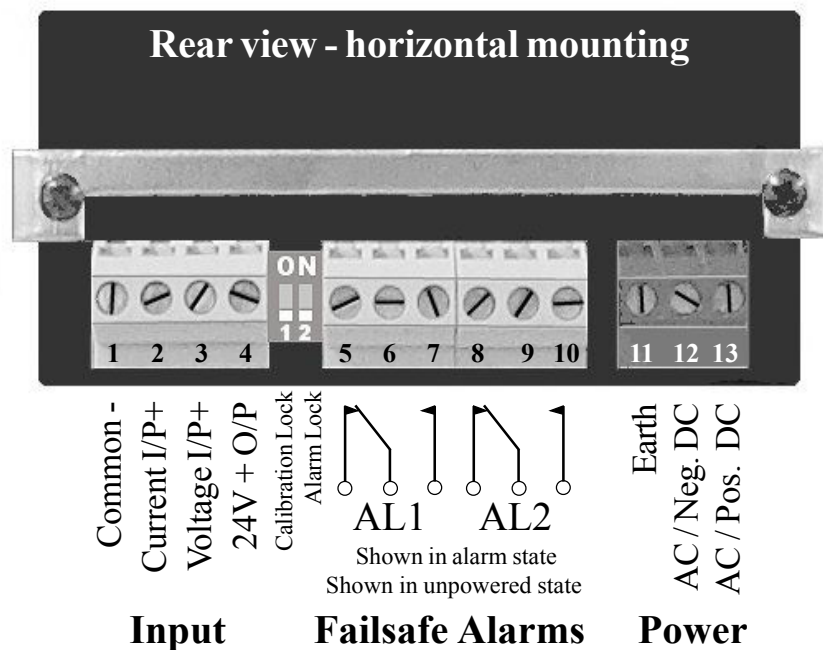

How to prepare and install your bargraph meter

First, check that the meter will suit your application and the available power source (either 95-265 VAC or 11-30 VDC). If you asked us to configure the meter, check that the scaling and settings agree with what you asked for.

We tested and calibrated your meter before we sent it to you, but a pre-installation test may be useful to check that everything works as you need. Check that all the switches behind the front bezel suit your application, before you install the meter.

Check that your panel cutout is 92mm x 45mm . It can be vertical or horizontal.

The meter's model number tells you which format to use.

A letter 'V' in the model number means vertical mounting, eg BAR-X-V-230A

A letter 'H' in the model number means horizontal mounting. eg BAR-A-H-110A

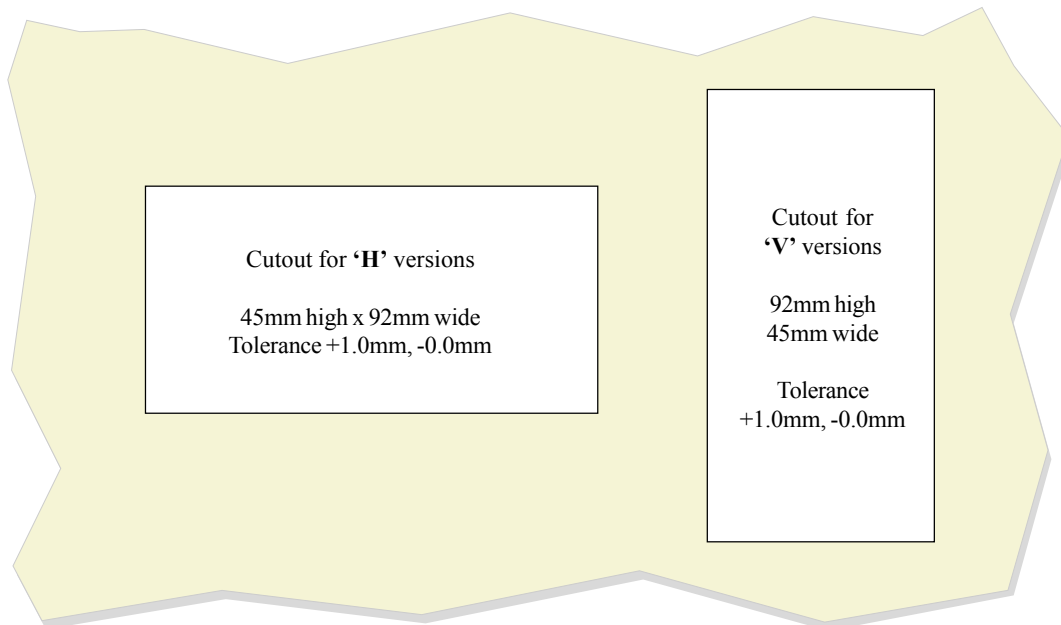

You must fit the meter in a protective enclosure. This is because the power terminals on the rear of the meter are exposed and carry dangerous voltage levels. If you want to mount it in an area where liquid may splash onto the display, you should also fit a splashproof cover, type SPC4, for protection to IP67.

Remove the 2 screws holding the U clamp at the rear of the case and all the connectors. Slide the meter into the cutout and re-fit the U clamp and screws. Tighten the screws just enough to hold the meter firmly in place.

Check that the power supply is suitable for the unit **before** you connect and switch on. Connect the signal and power cables (and relay connections for the BAR-X), to the correct screw terminal connectors.

Input and excitation examples

1. DC Current input such as 4-20mA, 0-10mA, 0-20mA etc.

The standard bargraph can accept DC current inputs such as 4-20mA. You can also connect signals such as 0-20mA and 0-10mA. These can be scaled using the front panel pushbuttons.

You can use the internal standard 24V DC excitation supply to power 2 wire 4-20mA transmitters. You must not take more than 30mA from the 24V excitation.

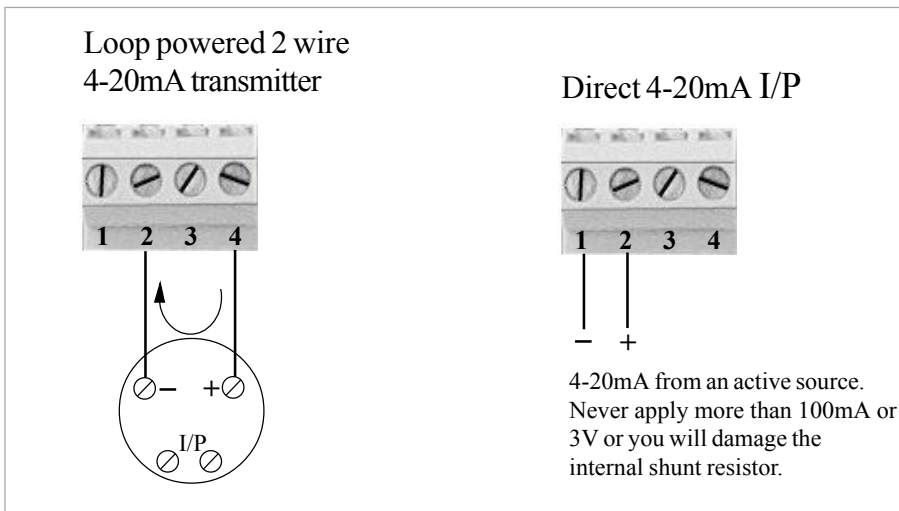

2. DC Voltage input such as 1-5V, 0-10V 0-5V etc.

The voltage input port can accept 0-10V as standard. You can also connect signals such as 0-5V and 1-5V, which you can scale with the front panel pushbuttons.

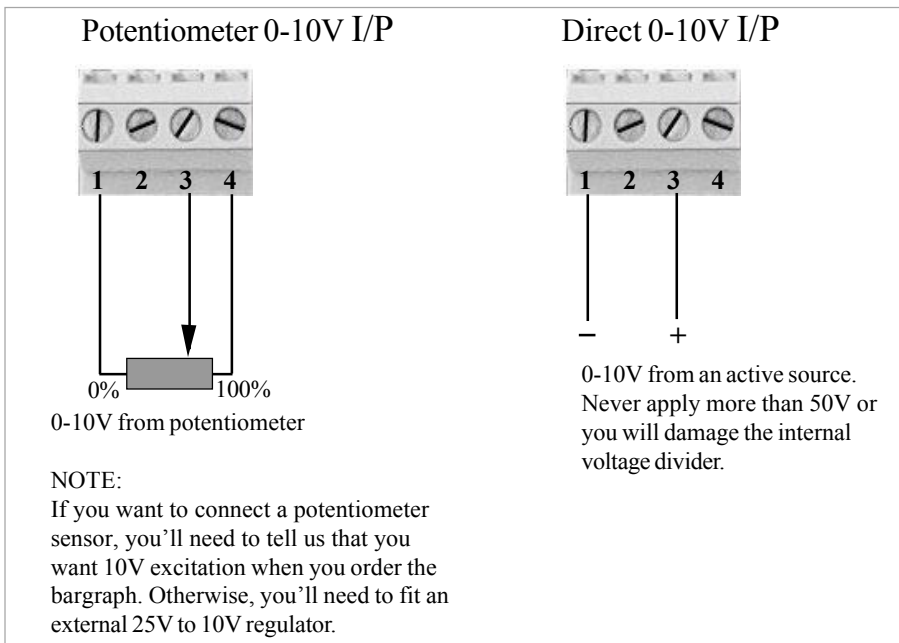

How to calibrate your display - Factory set ranges

1. There are two standard scales, which we've stored in memory for you.

* 4-20mA = 0-100% of scale

* 0-10V = 0-100% of scale

To choose one of these ranges, remove the front bezel, to expose the setting switches.

Set the switch position to suit your input signal, as below.

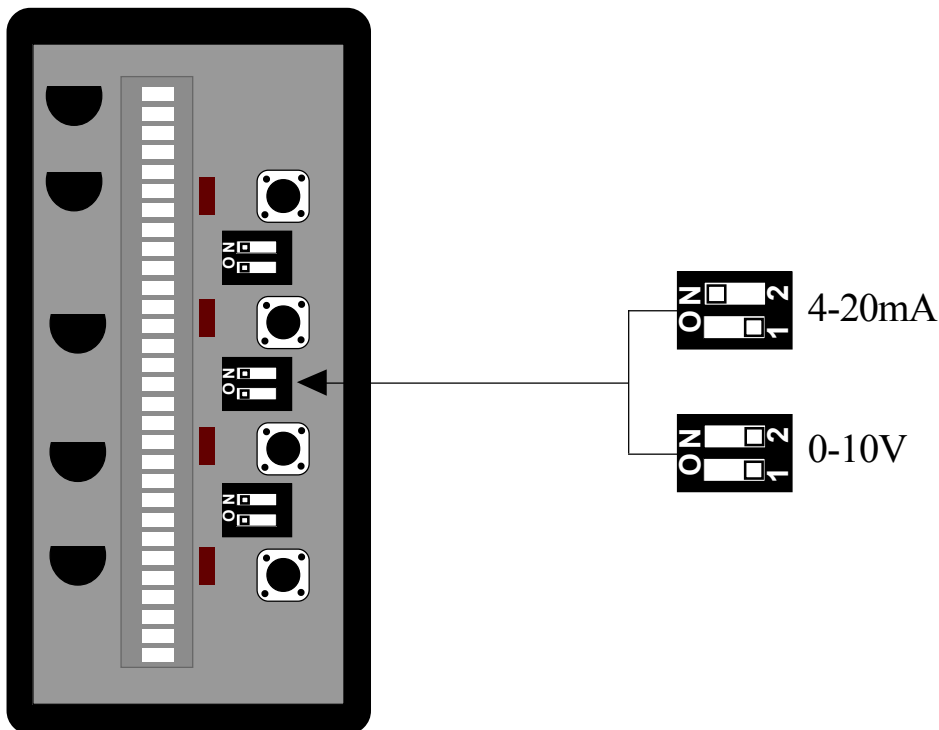

If the input signal falls below 4mA or 0V, the bottom LED will flash at one flash per second.

If the input signal rises above 20mA or 10V the full scale display will flash at one flash per second.

If your input signal range isn't exactly 4-20mA or 0-10V for 0-100% scale, see the next few pages, where you'll learn how to make and install custom scale labels, and how to do a non-standard calibration.

Scale sheet options

The default scale is 0-100%. If you'd like a different scale, for example 0-400 litres, -10 to +10 °C, 0-20kg etc., tell us on your order and we'll prepare and fit your scale for you.

If you're not sure what scale you'll need, you must tell us on your order that you haven't yet decided, so we don't fit the 0-100% default. This is because you cannot fit a new scale onto an old scale. You'll need a fresh front window if you want to change a scale.

You can search a library of high resolution printable .pdf scale sheets on the internet at <http://www.london-electronics.com/barscales.htm>

If you can't find a scale to suit your needs, you can make your own scale sheet. You'll need an accurate drawing package and a high quality printer. Use this dimensioned drawing to plan your label. Print the scale label onto good quality plain paper, 60 to 90 gsm weight.

The 4 white dots help you to line up the label in the self adhesive front window.

The scale length is 74mm between the bottom segment datum point and the top segment datum point.

Fonts are bold Helvetica or Arial

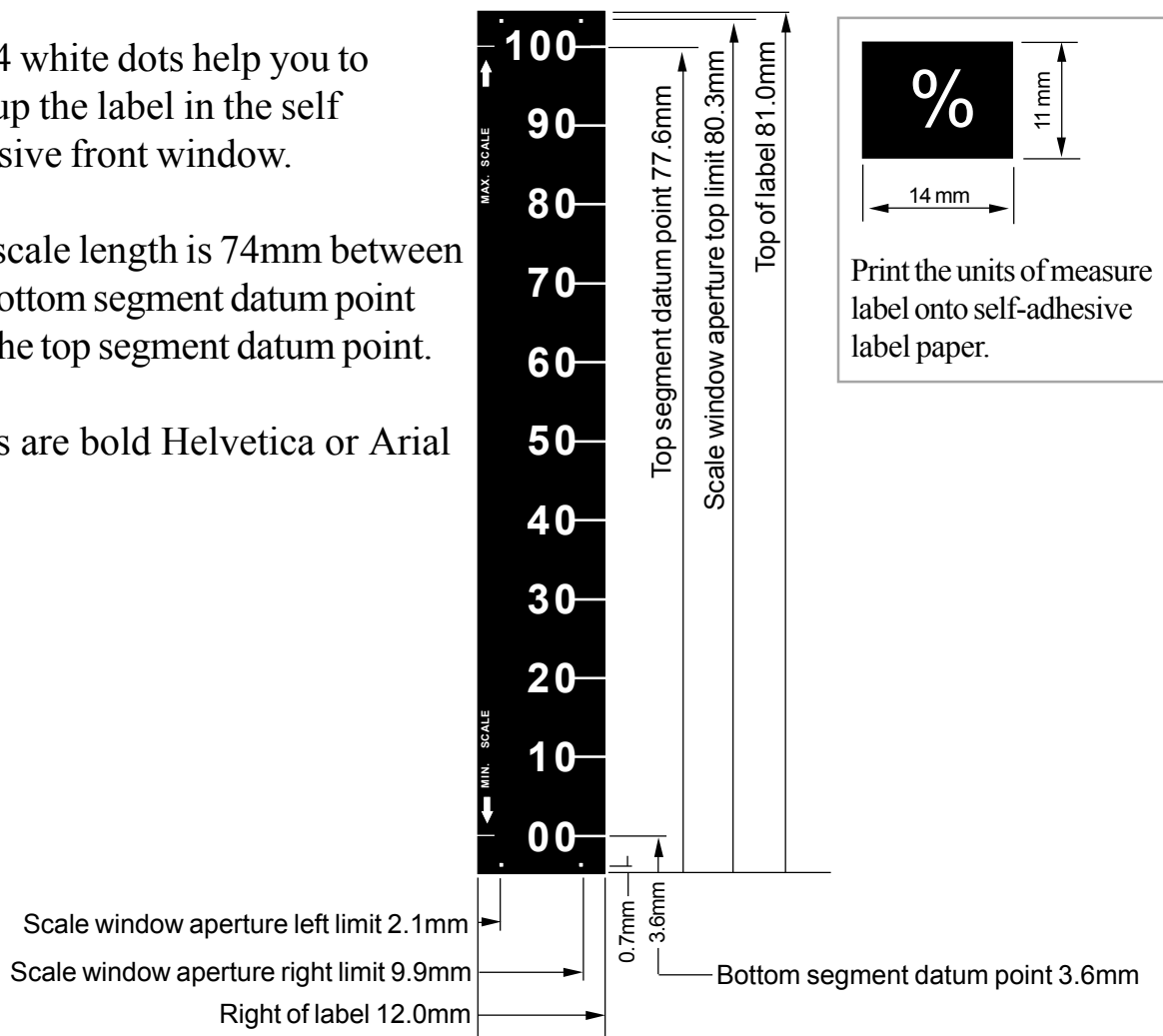

How to fit a custom scale sheet

1. Stick the units of measure label to the Plastic Bezel Frame...
2. Stick the Scale Sheet to the Self-Adhesive Window...
3. Stick the Self-Adhesive Window to the Plastic Bezel Frame...

Important: If you want to change an existing Bargraph's scale sheet you'll need a new Self-Adhesive Window and Plastic Bezel Frame. Use the re-order codes if you want to order new items

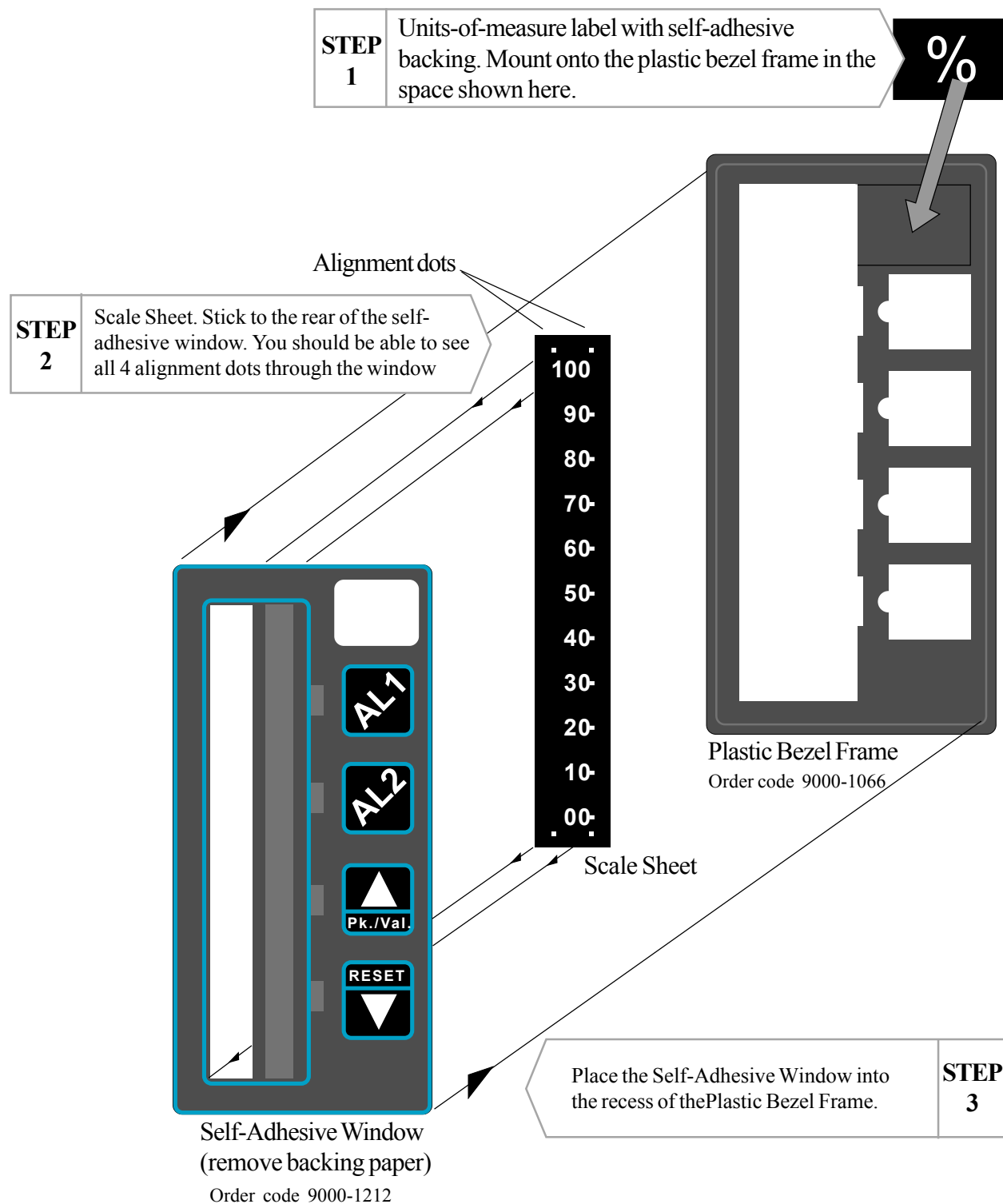

How to calibrate to your own signal range - ZERO

If you want to calibrate your display for signal levels which aren't exactly 4-20mA or 0-10V, you can 'teach' the bargraph your preferred signal levels and display ranges.

Remove the front bezel and set Adjustable Range 1 with the **middle set** of switches. Switch the rear calibration lockout switch OFF.



Inject your low signal level. Press the DOWN button for a few seconds. The red LED next to the DOWN button will flash. Release the button when the bar display is at the level you want for that input signal.

In this example, we're going to set the display to 10% of range when a tank is 10% full.

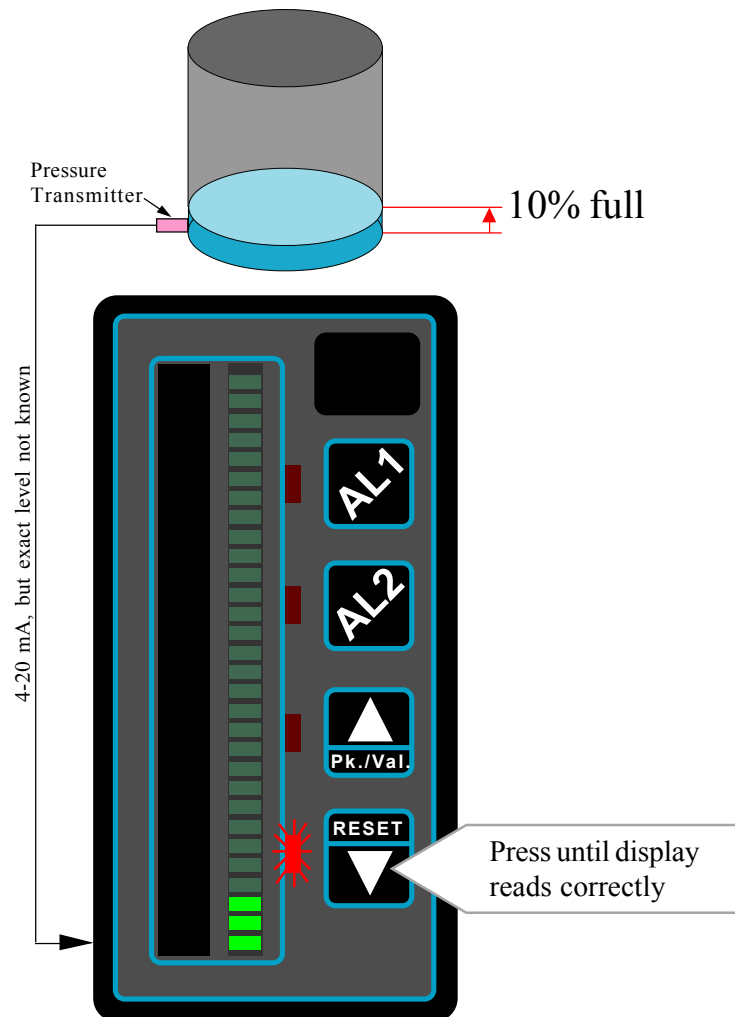

How to calibrate to your own signal range - SPAN

Now increase your input signal to a level you want to use for your high calibration point.

In this example, we want 90% tank level to read 90% on the bargraph.

Press the UP button for a few seconds. The red LED next to the UP button will flash. Release the button when the bar display is at the level you want for this input signal.

To save your settings, switch the rear calibration lockout switch ON and check that your display reads correctly for other input signal levels.

Your calibration is complete.

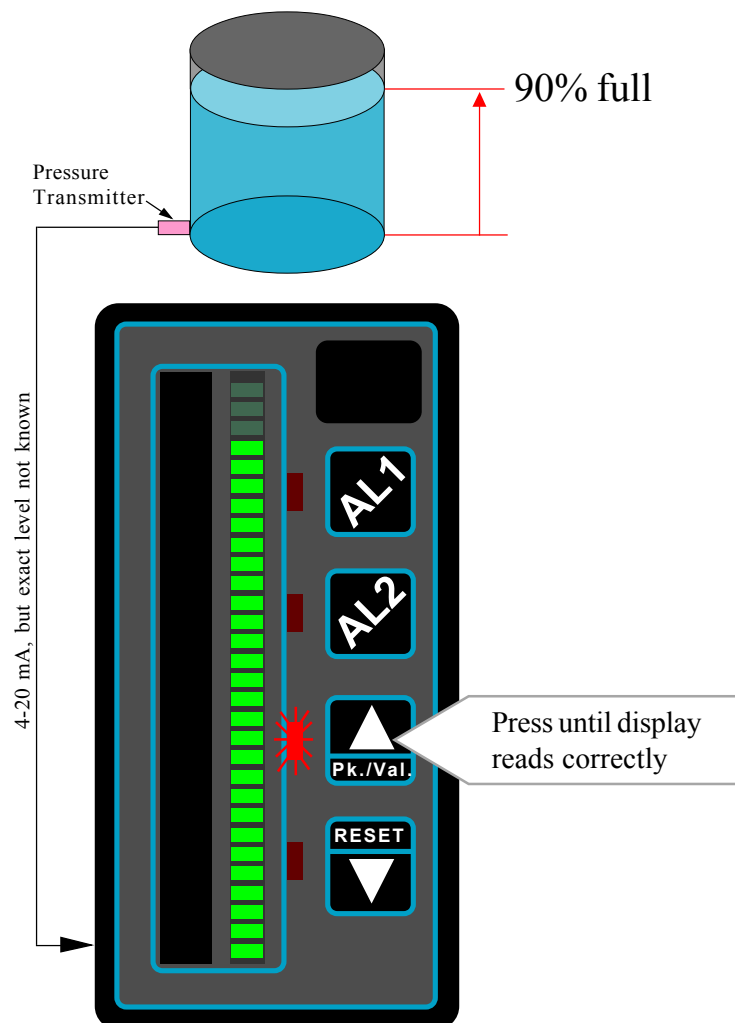

Alarm trip points - Alarm Lockout (BAR-X only)

You can view the alarm trip points at any time, but if you want to change an alarm trip point, you must first set the Alarm Lock switch OFF.

To lock the alarm trip point levels, so that they can't be changed, set the Alarm Lock switch to ON.

You'll find the Alarm Lock switch on the back of the bargraph, near the input signal connector.

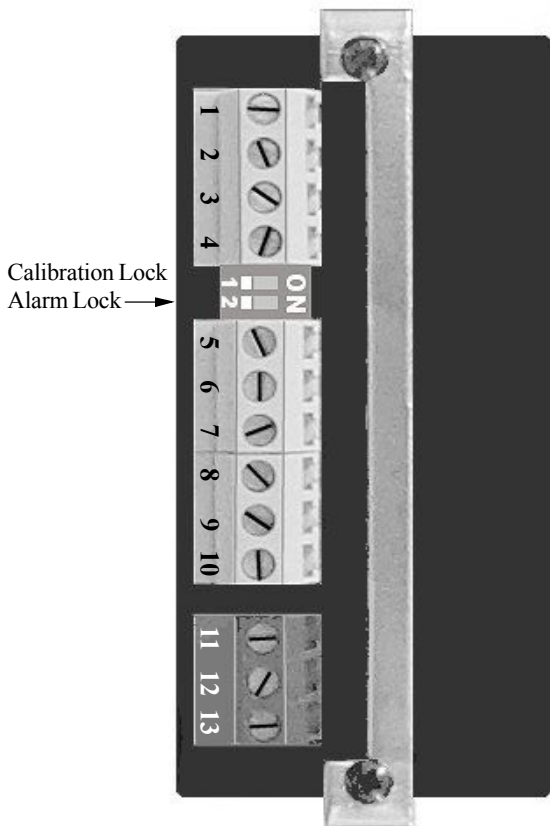

IMPORTANT SAFETY NOTE

Only change the Alarm Lock switch position when you have disconnected **all** power from the meter.

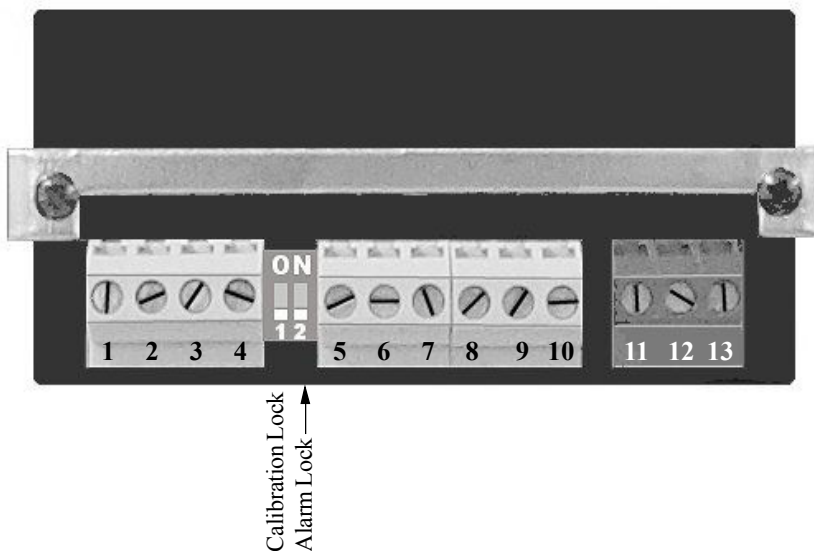

How to view and change alarm trip points (BAR-X only)

Press either AL1 or AL2 button at any time, to view their trip levels

To change a trip level, press either AL1 or AL2 button for around 3 seconds. At the same time, press either of the ARROW keys, to move the trip point to the position you want it. (The Alarm Lock switch must be OFF).

If you connect an analogue input signal, at the same level as the trip point you want, you can move the trip point up or down until it is **exactly** at the point where you see the alarm relay change over. If you keep your finger on the up or down button, the trip point will move in 1 segment chunks. If you want to set the trip point precisely, between segments, press the up or down button repeatedly to nudge it between segments. There are more than 50 steps between each segment, to give you a setting resolution of around 0.1% of scale.

When you've set both trip points, you should move the Alarm Lock switch to ON to prevent any further changes to the alarm level settings.

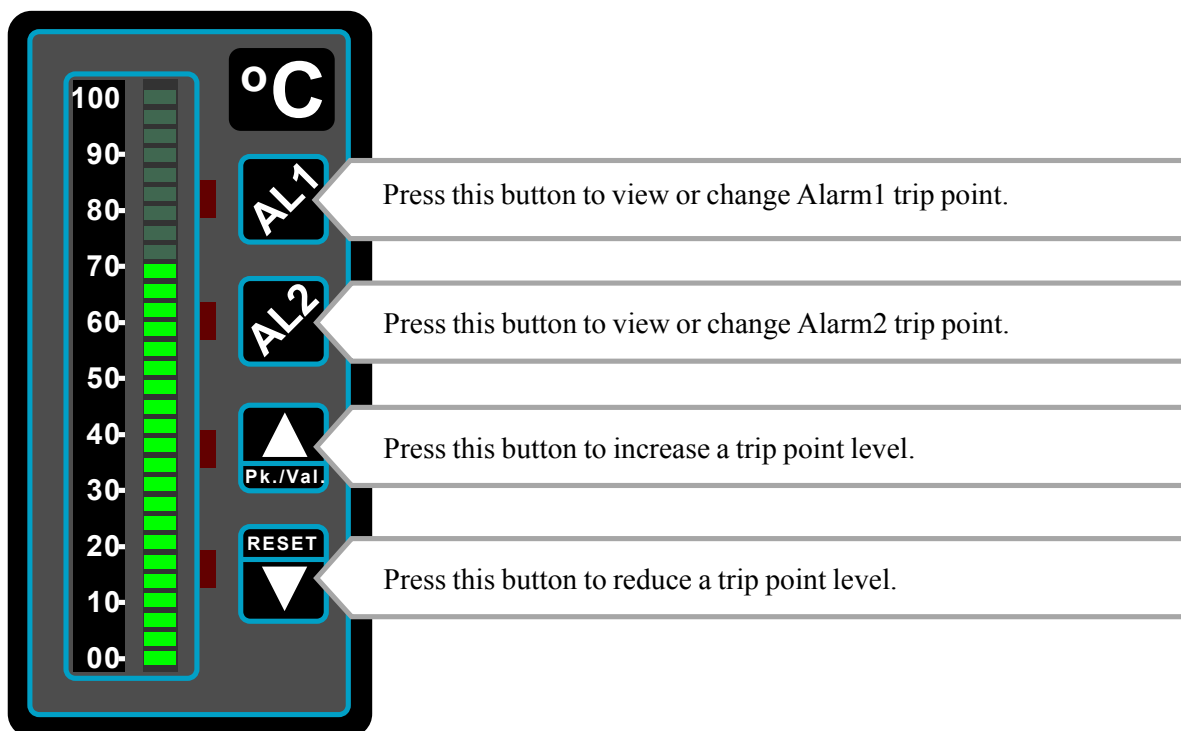

The alarm relays switch-off when they are in an alarm state (This is a failsafe action). When they switch off, a red LED next to the AL1 or AL2 button will light, to signal which alarm is active.

Pump-Control Alarm function (BAR-X only)

If you want to control the level of liquid in a tank or reservoir, the BAR-X pump-control function may be useful. This uses one relay (AL1) to control a refill pump.

Set minimum and maximum liquid levels. The BAR-X will allow the level to drop to the minimum level. When it reaches this minimum level, it will switch the fill-pump on.

The pump will run until the level reaches the maximum trip point level you set. The pump won't restart until the level drops to the minimum trip point level again, some time later. This helps to increase pump life, because it won't be switched on and off as frequently as it would be if a single level alarm is used.

The control action is failsafe. This means that if power is accidentally lost to the BAR-X controller, the pump will shut off.

Important: AL1 must always be set higher than AL2 in pump control mode.

Pump Restart: If you want to restart the pump before the level reaches the lower limit, press the RESET button on the BAR-X front lens. The pump will stop when the level reaches the high limit AL1.

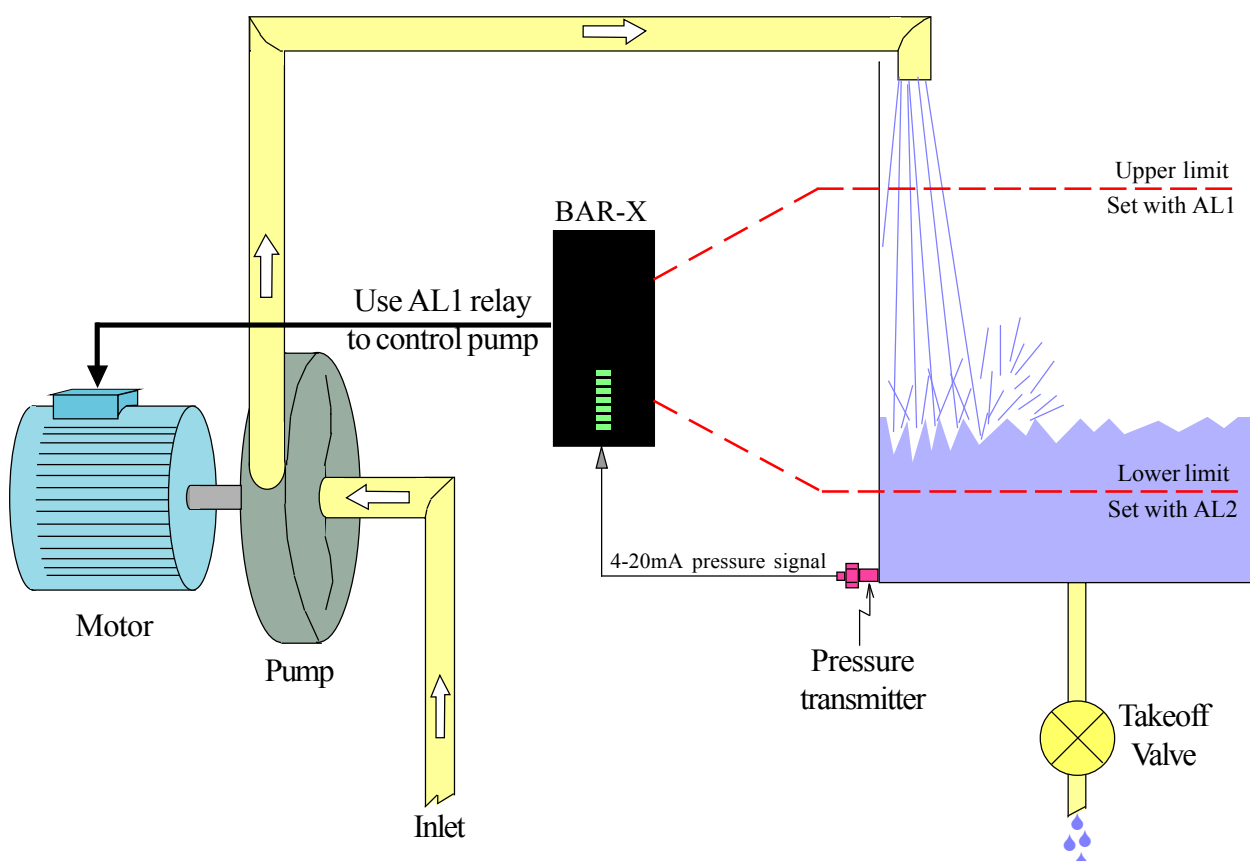

Peak and Valley (Min. and Max.) memory

The bargraph will store its highest and lowest readings in a temporary memory. The Calibration Lock switch must be ON.

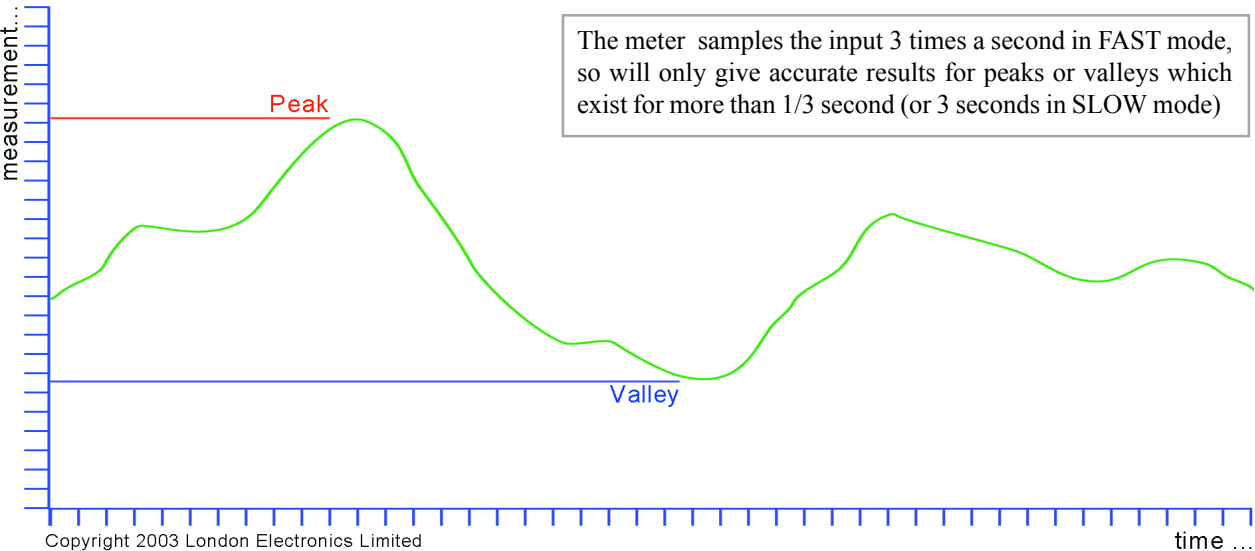

To see the peak and valley readings, press the Pk./Val. pushbutton briefly. Each press will alternate the display from peak to valley. The display will return to input value after a few seconds.

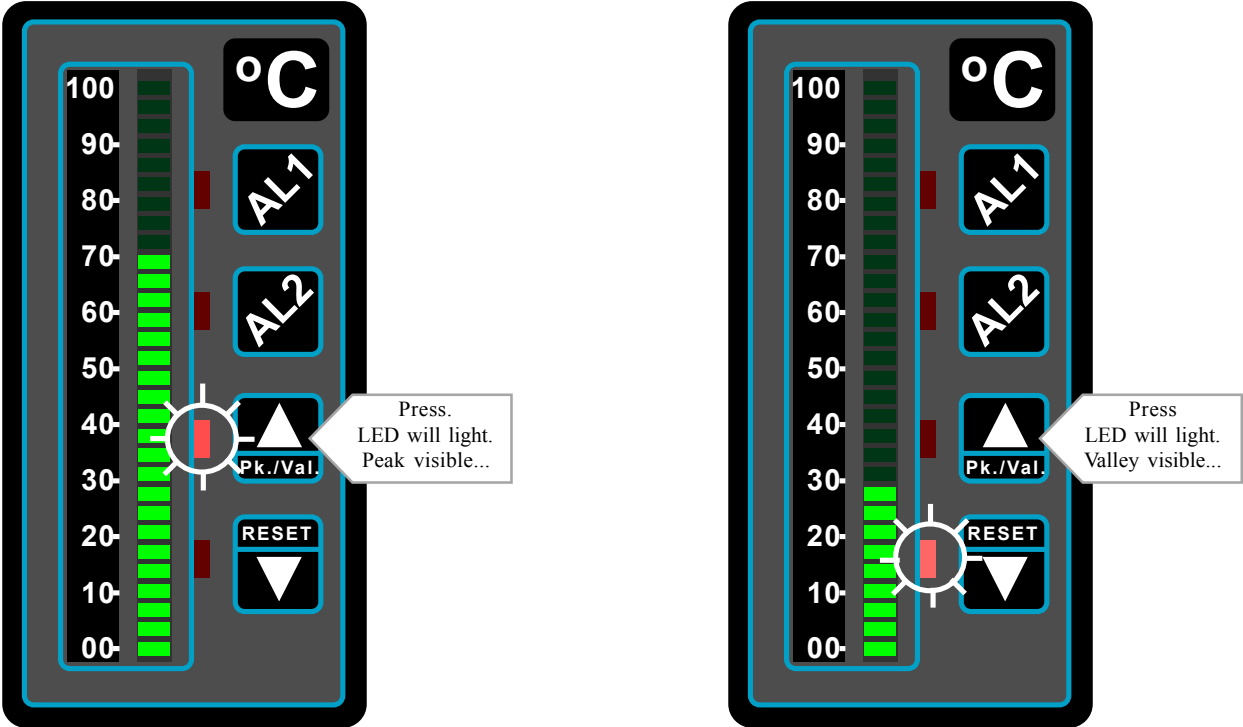

To clear the memories, press the RESET pushbutton for more than 3 seconds. The stored readings are also cleared whenever the bargraph is switched off.

The Reset button

The bargraph will store several items of temporary data. These are :

- * The highest reading since the meter was last reset.
- * The lowest reading since the meter was last reset.
- * In pump-control mode, the 'relay-latch' signal is stored while the container empties.

To clear these items of data, press the RESET pushbutton for around 2 seconds. The red LEDs near the up and down buttons will flash briefly when the reset happens.

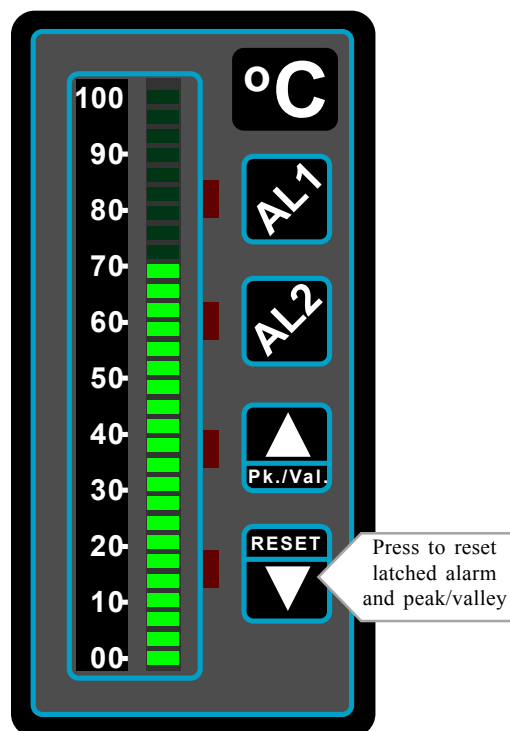

The peak and valley memories will now have the value of the measurement at the time the reset button was pushed. They will automatically change as the input signal rises or falls.

Specifications

Bezel size	48mm by 96 mm (1/8 DIN)	
Panel Cutout	45 mm by 92 mm	
Case Depth	125 mm including connectors	
Weight	300 grammes	
Case Material	Black polycarbonate	
Connectors	Detachable Screw Terminal connectors	
Operating Temp.	0 to 50 degrees C, non condensing humidity	
Storage Temp.	-10 to 70 degrees C	
Power supply	95-265 VAC or 11-30 VDC optional. Fully isolated.	
Power consumption	4 watts maximum	
Input Signal Ranges	+/-20mA	+/-10V
Operating Overload	+/-22mA	+/-12V
Maximum Overload	+/-100mA	+/-50V
Input Resistance	33 Ohms +/-2%	1 Megohm nominal
Display type	Red or green LED, 30 segment bargraph	
Accuracy	Resolution +/-3%	
Repeatability	Better than 0.2%	
Span tempco	100ppm/Degree Celsius max. typically	
Zero Tempco	50ppm/Degree Celsius typically	
Excitation voltage	24VDC +/- 10% rated at 30mA. Noise 200mV max (50Hz-100KHz)	
A/D conversion	Dual slope +/-1000 count maximum resolution	
CMRR	100dB 0-60Hz. 250V max.	
NMRR	20 db at 50/60 Hz.	
Display update rate	1/3 second fast mode, 3 seconds slow mode (to 100%)	
Memory	10 year data retention. No batteries required.	
Relays (BAR-X)	2 relays SPCO . De-energise on trip (failsafe)	
Contact rating	5 Amperes at 250 VAC, resistive load	
Precision	Typically +/- 0.1% settability	
Hysteresis	Typically 0.5% of range	
Latching (if set)	Relay will stay in alarm until manually reset from front	
Response speed	330mS fast mode, 3000mS slow mode	
Annunciation	Red LED annunciator for each alarm. Lit = alarm	

Record of Revisions

7 March 2003 Product released

Notes

Declaration of Conformity

Declaration Reference : BAR-X
Issue Date : 2 January 2003
Products Covered : BAR-A and BAR-X
Title : Bargraph display with alarm option

This certificate confirms that we designed and manufactured this product to meet the following limits :

EN55011:1998 Conducted Emissions: Class B
EN55011:1998 Radiated Emissions : Class B
IEC50082-1:1992 Electro-Static Discharge Immunity: 8kV Air
IEC50082-1:1992 Radiated ElectroMagnetic field Immunity: 3V/m
IEC50082-1:1992 Fast Transient Immunity : AC 1kV, cable 500V

The product was designed and built to conform with the applicable sections of the following standards:

EN 61010-1:1995

and meets the requirements of Council Directive 89/336/EEC for Electro-Magnetic Compatibility.

Conditions

This product is allowed a worst-case error of 1% of its range during electro-magnetic disturbance. It must recover automatically when the disturbance stops, without the need for human intervention, such as resetting, power-down etc.

The product must be installed according to these conditions :-

Signal cabling must be routed separate from power carrying cables(including relay output wiring)
All signal cabling must be screened. The screen must be connected to the power earth terminal near the meter. The screen must not be connected to earth anywhere else.

Certified as true and correct, for and on behalf of London Electronics Ltd.

J.R.Lees - Director