

# London Electronics Limited



Thorncote Green, Near Hatch, Sandy, SG19 1PU, England

Tel: 01767 626444 Fax: 01767 626446 International prefix +44

E-Mail [easy4u@london-electronics.com](mailto:easy4u@london-electronics.com)

Web site with full catalogue, news, distribution details, <http://www.london-electronics.com>



## Model INTUITIVE-I

Totalising Digital Process Indicator / Controller  
4-20mA / 0-10V input

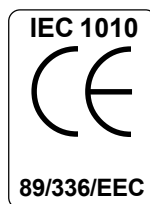
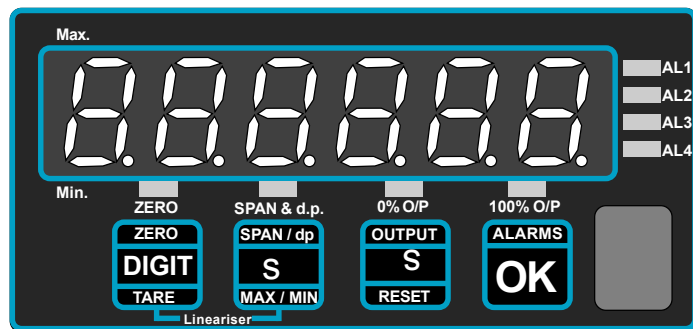

Patent App. Numbers :- UK=GB9820695.6, EU=99307553.0, USA 09/401738, Canada 2283378

Document Ref:pm65\manuals\INTUITIVE\_I Revision:4 Dated: 1 July 2009

# Alphabetic Index

Alarm board Configuration	11
Alarms, how to set	12
Analogue Output configuration	14
Analogue output, how to set	15
Calibration	6
Calibration Examples	7
Calibration - Tamper detection	9
Connections	5
Count-By (last digit round-up) adjustment	8
Decimal point position selection	6
Declaration of Conformity	20
Failsafe alarm setting	11
Filter time constant selection	8
General description	3
Getting Started	4
Hysteresis adjustment	12
In-Flight compensation facility	13
Installing options	10
Introduction	1
Input connection examples	5
Programme memory facility	17
Reset command	9
Revisions record	19
Serial Communications	16
Specifications	18
Warnings	2

## Important Introductory Notes

Please feel welcome to contact us if you need help, have a complaint, or if you have suggestions for improving our products or services.

If you contact us about a product you already have, please give us as much information as you can, so we can give you accurate and swift help.

**Software Version:** The display will show VEr. X.X shortly after being switched on. The value X.X is the software version which you must quote when contacting us about technical matters.

Our products have a 2 year warranty, and we will put right or replace any meter found to be faulty through bad workmanship or materials. This warranty does not cover damage caused by misuse or accident.

***IMPORTANT*** If the meter is a vital component in your process, you may wish to buy a spare to cover possible failure or accident, as we cannot guarantee instant repair or replacement. We always try to improve our products and services, so changes to instruments will occur. Please keep this manual safely for future reference, as future manuals, covering revised designs may no longer describe your product accurately.

We believe these instructions are accurate, and that we have competently designed and manufactured the product. We do not make any claims as to the suitability of this product for any particular application. The choice of product and responsibility for the choice lies with the User.

Our full terms and conditions of trading are available on request.

## Warnings



**Please carefully read all warnings and ONLY install the meter when you are sure that you've covered all aspects.**

\* Connect the meter according to current IEE regulations and separate all wiring according to IEC1010.

\* Power supplies to this equipment must be anti-surge fused at 125mA for 230V supply, 250mA for 110V supply or 1A for DC supplies in the range 11-30VDC.

\* Check that model number and supply voltage suit your application before you install the meter.

\* Don't touch any circuitry when the meter is powered, because lethal voltages may be present on the circuit board.

\* We have designed this product for Installation class II service.

\* We have designed this product for use in Pollution-Degree 2 environments.

\* Only adjust switches or connections with the power removed.

\* Ensure all screw terminals are tight before applying power.

***Safety First .....Don't assume anything..... Always double check.  
If in doubt, ask someone who is QUALIFIED to assist you in the subject.***

# General Description

This meter has been designed to be simple to configure. It is easy to use because no menu is used. Look at the front panel below... to adjust ZERO you press the ZERO button, to adjust Span you press the SPAN button, to adjust Analogue Output you press the OUTPUT button, to adjust Alarms you press the ALARM button. There is no need to spend time learning a complex menu system.

The meter's main function is to totalise (or integrate) from a linear process signal. So, it will accept the most common process signals such as 4-20mA, 0-10V etc. You can use the 24V excitation supply to power 2 wire transmitters, 3 wire transmitters etc.

The meter can give alarm outputs, scaled and isolated analogue output and isolated serial data retransmission when fitted with option boards.

The front panel has a 6 digit, 7 segment window for displaying the measurement. It allows decimal point and minus sign characters to be included and has 4 alarm annunciators to show the status of each alarm relay.

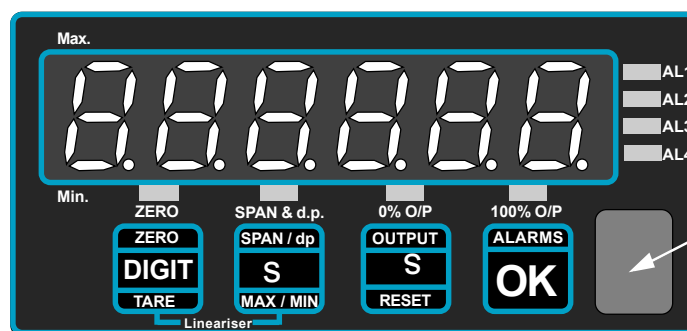

“Units of measure” window

The front panel pushbuttons each have an LED to show which setting is being altered at any time. A clear protective window is provided, behind which you can fit one of our ‘Units-of-Measure’ labels, to identify the reading as Kg, or Litres, barrels etc.

A lockout switch on the rear of the meter saves your configuration settings in non-volatile memory, which has a 10 year guaranteed storage period. If the lockout switch is not set ON, your settings could be accidentally altered.

## Getting Started

First, please check that the display will suit all the requirements of your application. Page 4 has some important warnings - please check that all warnings are covered.

If you have analogue output or alarm relay options, you may need to configure their boards before installing the meter in a panel. See the separate sections in this manual for those options.

Check that your panel cutout is correct , 92mm wide, 45mm high. You must fit the meter in a protective enclosure for installation class II service. Remove the 2 screws holding the U clamp at the rear of the case. Slide the meter into the cutout and re-fit the U clamp and screws. Tighten the screws just enough to hold the meter firmly in place and make sure the sealing gasket is evenly held between the panel and the bezel.

Connect the signal and power cables, to the appropriate screw terminal connectors. Check that you are using the correct terminals or you may cause damage to the meter. Do not connect any output or alarm cabling yet.

Apply power, and confirm that the meter illuminates all segments for a few seconds and then shows the software version “VER. X.X” briefly (The X numerals depend on version).

The lockout switch should be OFF to allow you to change the meter’s settings. Set the scaling to suit your system, using one of the scaling methods described in this manual. Check that the meter responds correctly. Now, adjust your analogue output settings, if necessary, and alarm settings. Use a DVM of sufficient precision to check that the analogue output is operating as required, and use a continuity tester to check that the relay contacts operate correctly. Switch the meter off, and check alarm relay contact status. Check that the contact status suits your system, in conditions of power loss to the meter.

When you have verified all settings, you can connect the alarm relay and analogue output cables, to check that your system operation is satisfactory.

Remember to set the lockout switch ON when you have finished , to prevent accidental loss of your settings.

# Connections

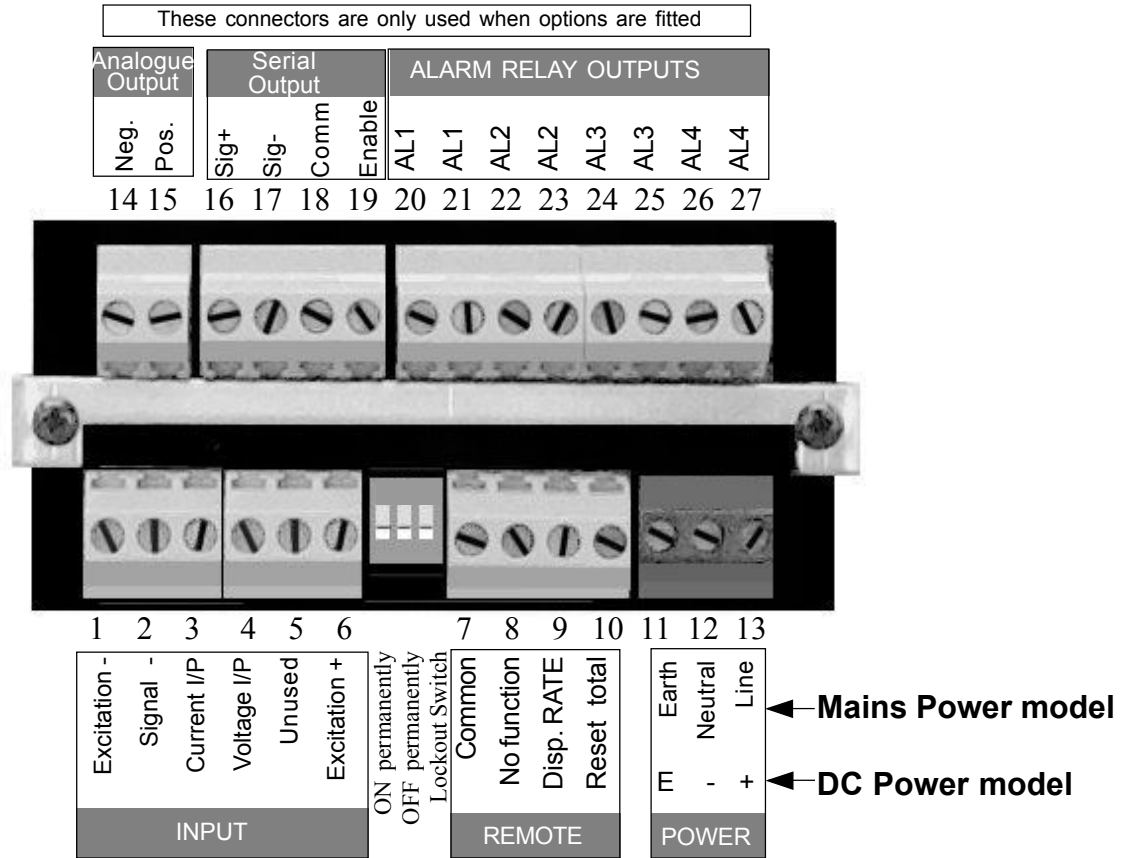

**NB - Switches have changed! Red switches had ON=UP. Blue switches have ON=DOWN**

Cabling should be screened and routed away from noise-carrying cables and machines to reduce interference. The screen can be connected to power earth if it is not already grounded at the sensor end.

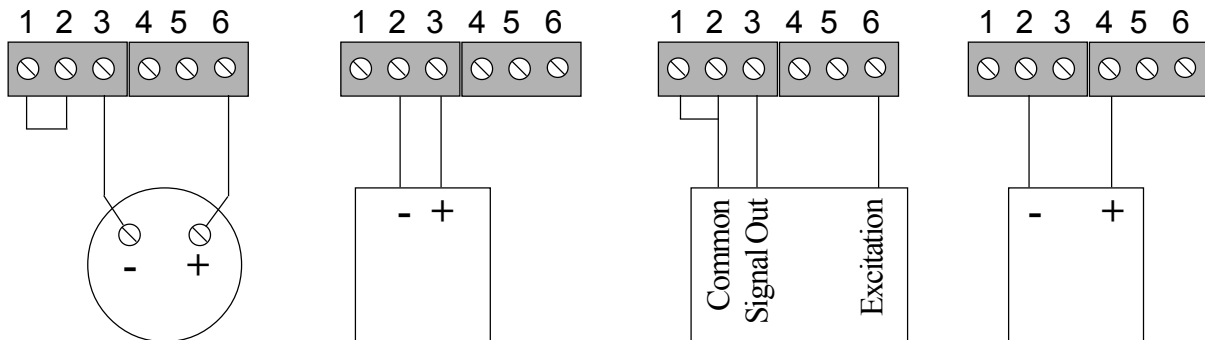

4-20mA 2 wire transmitter

4-20mA direct

4-20mA 3 wire transmitter

0-10V direct

## IMPORTANT!

Set the right-hand switch to its upper 'LOCK' position after setup, to save your settings.

# Calibration

**Set switch 1, near the input connector ON and lockout switch OFF**

## 1) How to set SPAN and DECIMAL POINT

Press the SPAN button for 3 seconds. You'll see 'dC V' or 'dC A' if the meter is set for DC Voltage or DC current. Use the up or down arrow to change, if needed and then press OK.

You will now see 'Int H' or 'Int d' to allow you to calibrate in counts per hour or day. Select the most appropriate, and press OK

You'll now see 'In HI' briefly, then a value, with one digit brighter than the other. This is 20.000 for a 4-20mA input signal, or 10.000 for a 0-10V input signal, 5.000 for a 1-5V input signal and so on. If the value is correct, press the 'OK' button, otherwise use the 'DIGIT' key to select digits, and the 'UP' or 'DOWN' arrow keys to alter. When correct, press the 'OK' button.

'rd HI' appears briefly, then a value, with one digit brighter than the other. This is what will be displayed for the IN HI input, at full scale, after 1 hour or 1 day, depending on whether you chose 'Int H' or 'Int d'. If the value is correct, press the 'OK' button, otherwise use the 'DIGIT' key to select digits, and the 'UP' or 'DOWN' arrow keys to alter. The *Decimal point* position may be set after the most significant digit has been selected. When correct, press the 'OK' button.

*See the following page for examples ...*

## 2) How to set ZERO

Press the ZERO button for 3 seconds. You'll see 'IN LO' briefly, then a value, with one digit brighter than the other. This is 4.000 for a 4-20mA input signal, 0.000 for a 0-10V input signal, 1.000 for a 1-5V input signal etc. If already correct, press the 'OK' button. Or, use the 'DIGIT' key to select digits, and the 'UP' or 'DOWN' arrow keys to change. When correct, press the 'OK' button.

You'll now see 'LO rd' briefly, then a value, with one digit brighter than the other. This is what will be displayed for the IN LO input. If already correct, simply press the 'OK' button. Or, use the 'DIGIT' key to select digits, and the 'UP' or 'DOWN' arrow keys to change. When correct, press the 'OK' button.

*See the following page for examples ...*

**Now, please set the LOCKOUT switch ON to protect your settings**

# Calibration Examples

1. 4 to 20mA = 0 to 300m<sup>3</sup> per day flow rate.  
You want to display total m<sup>3</sup> passed
  - a. Set '**Int d**' because your flowrate is described in m<sup>3</sup> per **day**
  - b. Set InHi = 20.000mA
  - c. Set rd Hi to 300 (after 24 hrs at 20mA, the display will reach 300)
  - d. Set InLO to 4.000 mA
  - e. Set lo Rd to 0 (At 4mA you want no accumulation)
  
2. 4 to 20mA = 0 to 100 litres per hour  
You want to display total litres, to 2 decimal places.
  - a. Set '**Int H**' because your flowrate is described in litres per **hour**
  - b. Set InHi = 20.000mA
  - c. Set rd Hi to 100.00 (after 1hr at 20mA, the display will reach 100.00)
  - d. Set InLO to 4.000 mA
  - e. Set lo Rd to 0 (At 4mA you want no accumulation)

# Filter and Last Digit Roundup

Press the OK button 5 times to access the filter time constant, which is expressed in seconds. You can use the filter to improve your display stability with fluctuating input signals. Use the UP and DOWN buttons to select a time constant in the range 0 to 5 seconds. Bigger time constants give more stability but slower response. Press OK when selected.

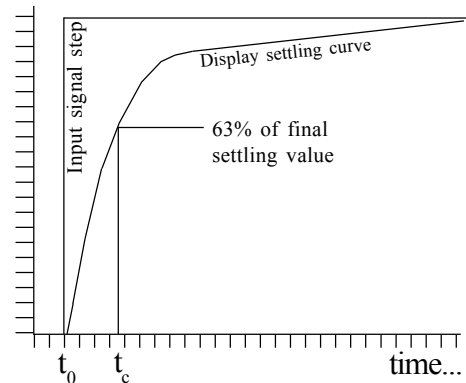
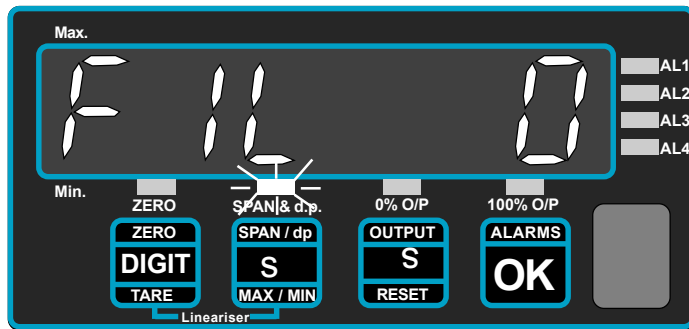

The Time constant of this digital filter is very similar to the time constant of an RC filter where  $T=RC$ . The time constant is the time it takes for the display to reach 63 % of its final reading value, after a step change on the input. You can see that if you select a 1 second filter time, it will take several seconds for the meter to reach its final value. To give improved response to large step changes, we momentarily cancel the filter action for stable input step changes of over 64 counts, and then re-apply the filter to maintain stability.

Another function which can give you a more stable display, with less flicker is the LAST DIGIT ROUNDUP.

After the filter setting, the display will show LSt and a number. This number sets the increments by which the meter will change its reading.

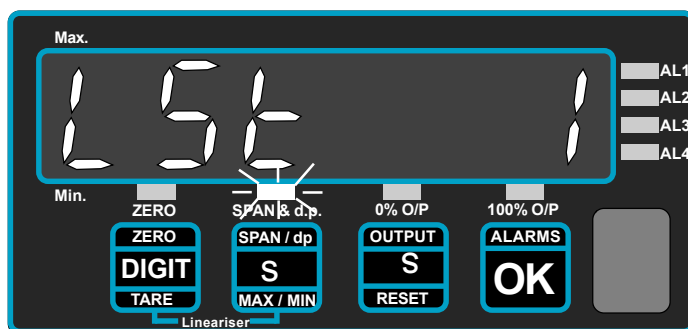

Use the UP/DOWN buttons to select a roundup value, and accept by pressing OK.

- |   |                            |
|---|----------------------------|
| LSt = 1 Best resolution, but most sensitive to noise. | Sequence 0,1,2,3,4,5,6 ... |
| LSt = 2   | Sequence 0,2,4,6,8,0...    |
| LSt = 5   | Sequence 0,5,0,5...        |
| LSt = 10  | Sequence 0,10,20,30...     |
| LSt = 20  | Sequence 0,20,40,60...     |
| LSt = 50 Lowest resolution, least sensitive to noise  | Sequence 0,50,100,150...   |

# Features

## **Calibration Counter / Tamper detector**

An internal totaliser counts each calibration. The 'CAL XX' value appears for a second or two after you switch the meter on. The number starts at 00 and can go up to FF (255 counts). It doesn't count changes of setpoints, or changes of filter value or count-by value. It stores the total in non-volatile memory which can't be reset, so is useful for keeping track of the meter's calibration history.

## **Reset Command**

The reset command clears the accumulated total. It may be accessed either from the front panel or by external contact closure command.

## **Front Panel key reset command**

- 1) Link terminal 7 to terminal 10
- 2) Set lockout switch 'ON'
- 3) Press Down Arrow key to reset display

## **Remote contact closure resetting**

- 1) Connect a normally-open contact closure switch between terminals 7 and 10
- 2) Set lockout switch 'ON'

## **Display Rate Command**

The 'display Rate' allows you to see the instantaneous flow rate. It may be accessed either from the front panel or by external contact closure command.

## **Front Panel key rate display command**

- 1) Link terminal 7 to terminal 9
- 2) Set lockout switch 'ON'
- 3) Press Down Arrow key to see rate

## **Remote contact closure rate display command**

- 1) Connect a normally-open contact closure switch between terminals 7 and 9
- 2) Set lockout switch 'ON'
- 3) When you make a contact closure between terminals 7 and 9, the display will show the instantaneous rate value, for as long as the contact is closed.

# How to install option boards

If you want to open the meter to install or modify option boards, follow these steps...

- 1) Switch off power to the meter and unplug all connectors.
- 2) Unclip the front bezel. This is easier if you squeeze the top and bottom of the case, near the front.
- 3) Remove the small screws shown in the diagram. If the meter doesn't yet have an output option board, the top screw may not yet be fitted.
- 4) Slide the electronic boards out through the front of the case. You can easily separate the upper option board from the main board. We strongly suggest that you use anti-static precautions to prevent damage to the semiconductors.

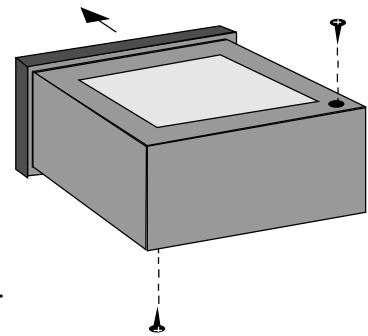

The board assemblies will look something like this...

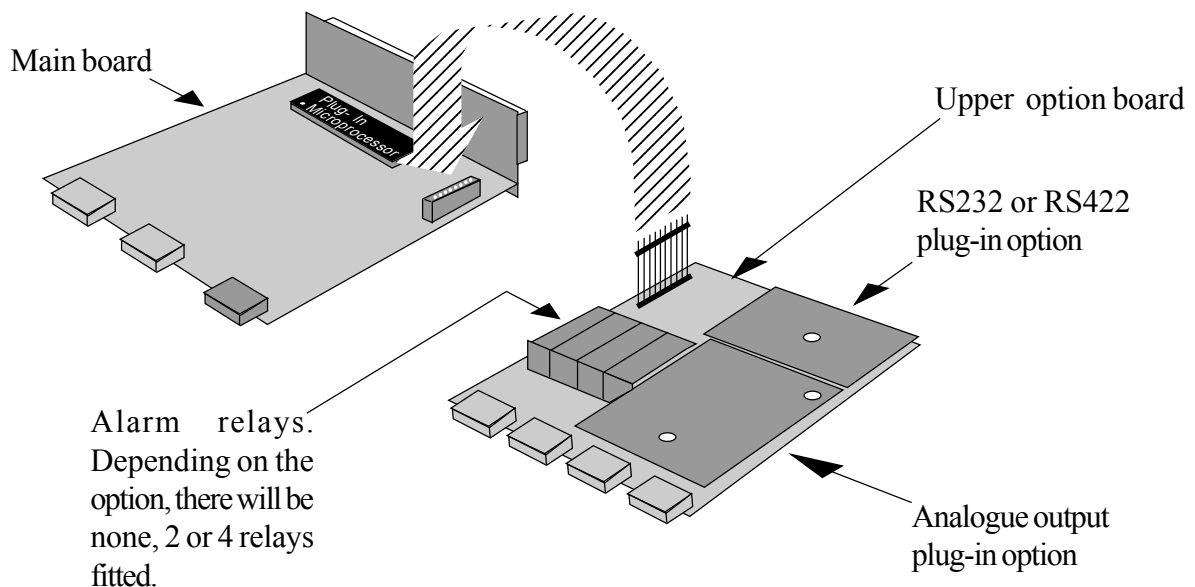

The analogue output and RS232 or RS422 plug-in option boards are fixed to the upper option board with white plastic pillars. You must apply a firm force when fitting or removing these options.

Always be careful to connect the pins to sockets accurately. When reassembling, make sure option boards are firmly fixed to the upper option board. When the boards are replaced in the case, secure them again with the two small black screws.

# Alarm Board Configuration & Adjustment

For failsafe operation (where contacts open on alarm or when power is lost to the meter) set the jumpers for OPEN CONTACTS and DE-ENERGISE on alarm.

To access to the alarm board, first remove power from meter, including any power which might be on the alarm output circuitry.

Look on the top and bottom surfaces of the case, near the rear. You will see two small screws, one on each surface. Remove both screws. Now, clip off the front bezel and slide the meter assembly carefully out via the front of the case.

The relay board plugs into the main board. Gently separate the two boards.

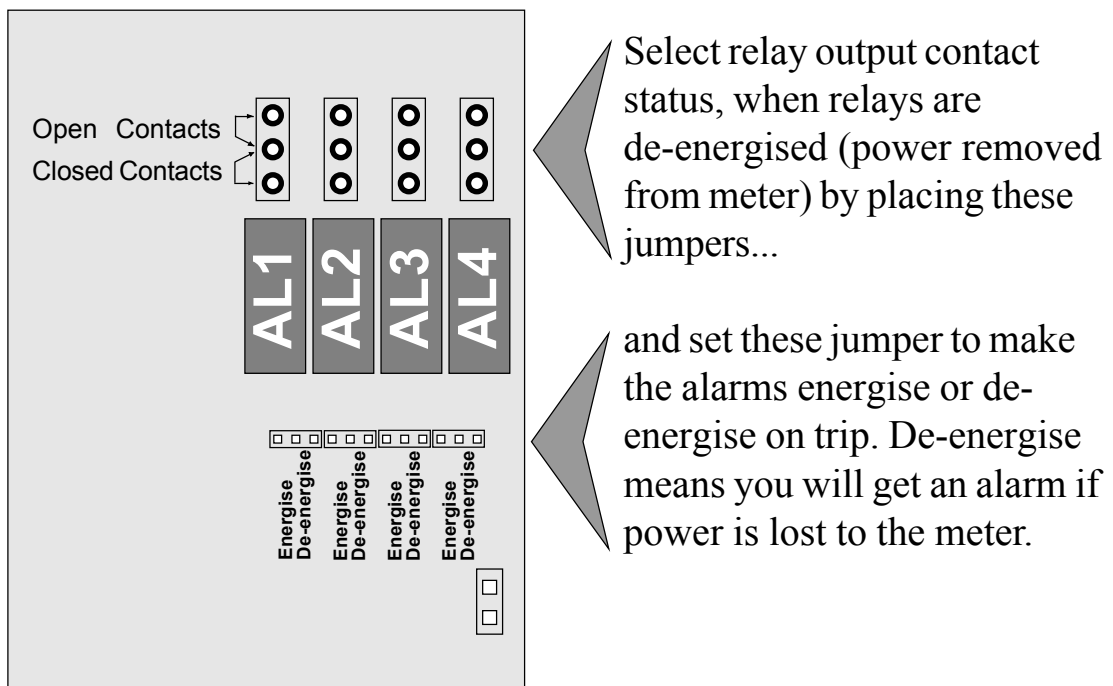

When you have set the jumpers, refit the board to the meter and carefully slide the assembly back into the case.

Fit the two small board screws to the top and bottom surfaces.

## Alarm settings

If you press the ALARMS button momentarily, you can view each of the 4 alarm settings (each press will illuminate in turn AL1, AL2, AL3 and AL4 LEDs). Alarm settings are not locked out by the lockout switch.

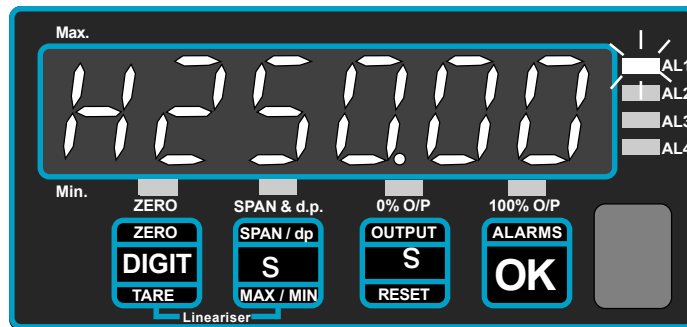

Alarm channel LED will flash.

Here, we see that Alarm 1 is a high alarm with its setpoint at 250.00

To change alarm settings, select the alarm you wish to change as shown above until its LED is flashing, then press the ALARM key for more than 3 seconds. You will see one digit is brighter than the others. You can change its value using the UP/DOWN buttons, and then select other digits with the DIGIT SELECT pushbutton.

The alarm action is determined by the left-hand character. This will show an 'H' for HIGH alarm action, an 'L' for LOW alarm action, or a 'o' for NO alarm action. You can change this with the UP/DOWN buttons. Press OK when set.

The HYSTERESIS value is identified with a 'HY' prompt, and you can change this to suit your requirements, in the same way as the alarm value.

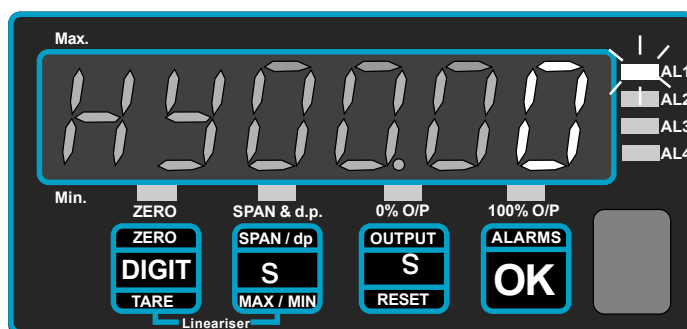

The hysteresis value is directly related to your measurements, so, for example, if you have a high alarm, set to 500, and set the hysteresis value to 7, the alarm will occur when the meter reading rises above 500, and will reset when the meter reading falls to 493. If the hysteresis is set to 9999, the alarms will be provided with 'IN-FLIGHT' compensation (automatic correction for overshoot)

# In-Flight Compensation

You can configure the meter to have in-flight compensation, which can improve alarm accuracy in some applications.

Here's how it works....

Imagine you have a storage container and you want to empty a certain amount of material from that container into a bin.

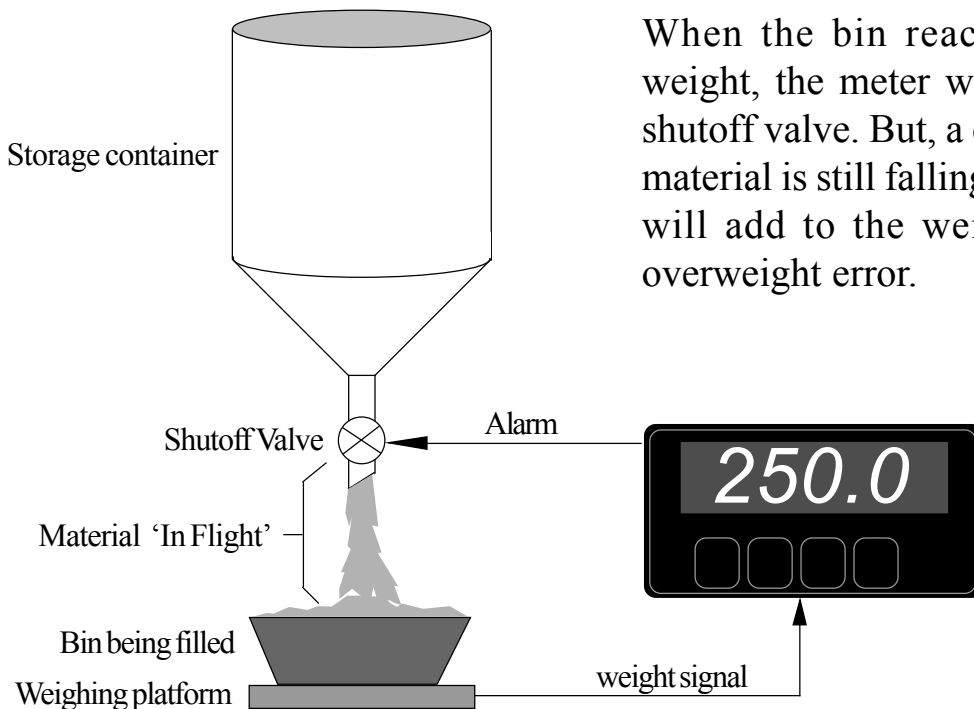

When the bin reaches the desired weight, the meter will switch off the shutoff valve. But, a certain amount of material is still falling into the bin, and will add to the weight, causing an overweight error.

The meter will automatically compare the desired setpoint level to the actual final fill or empty weight, or position, and compensate for any calculated error for the next cycle. This is a continuous process, so if material consistency varies and the in-flight error varies, the meter automatically adapts after each operation.

For the first alarm, the meter will correct for 100% of the measured error, to get as close to desired action as possible. Then, each time the alarm occurs, it will correct for 25% of the previous smaller error, to reduce the effects of material variations.

To use the in-flight compensation, set Hysteresis to 9999 for the alarm channels you need it to operate on.

# Analogue Output Configuration

We always set the meters to suit any requests on your order, so you should not need to adjust the analogue board. If you didn't specify ranges, but ordered option 'ANI', the meter will be set for 4-20mA output. If you ordered 'ANV' it will be set for 0-10V.

If you want to change a range, for example from 0-10V to 4-20mA, the zero and span potentiometers must be adjusted to get best accuracy at 0% and 100%.

You will need to remove the analogue board from the case to change the position of jumpers and to adjust the fine trim potentiometers. See the page headed "How to fit Option Boards" for details of how to expose this board. The analogue board, if fitted, can be seen plugged into the upper board, and can be easily identified because it has either 2 or 3 blue potentiometers, depending on version.

You will need to carefully unplug the analogue output board from the upper board and change the jumper positions to suit your new range, as shown below.

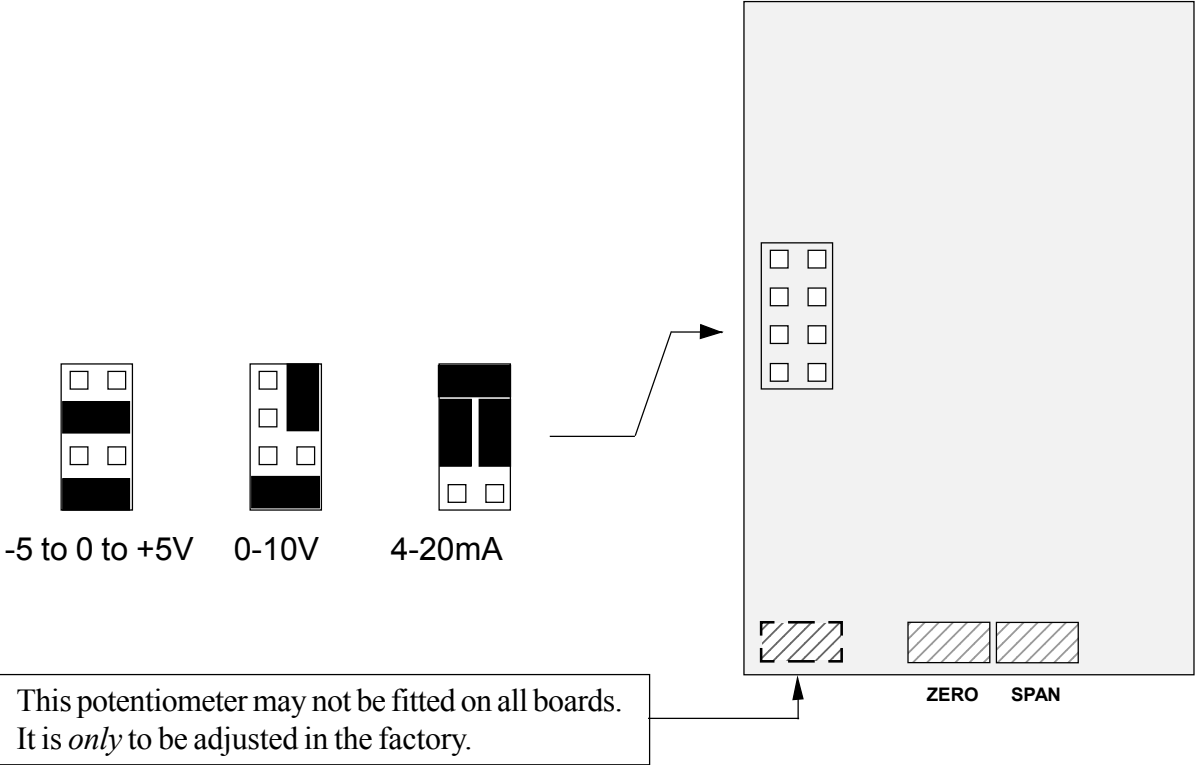

Re assemble the meter, apply power and follow the Analogue Output Settings procedure on the next page. Measure the analogue output and trim, if needed, using the ZERO and SPAN potentiometers, for best accuracy.

# How to adjust your Analogue Output

The lockout switch should be set 'OFF' to change the analogue output calibration. You can set the analogue output range to suit your display range.

The analogue output can be directly proportional or inversely proportional to the display range, for example you can have 4-20mA output for display 0 to100 or for display 100 to 0.

- 1) Press 'OUTPUT' button for 3 seconds
- 2) 0% O/P LED should flash
- 3) Set the display for the reading value where you want 0% Output, by using DIGIT and UP/DOWN buttons

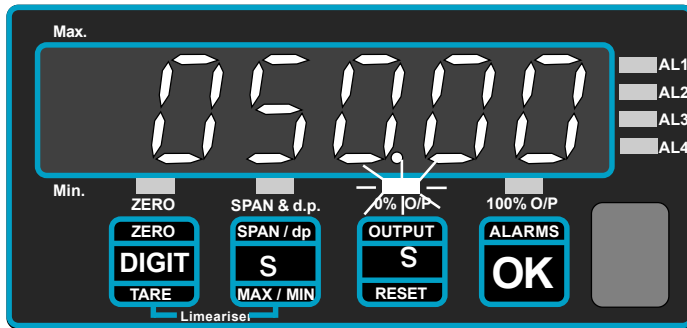

Jumpers on Analogue Board	0% gives
4-20mA	4mA
0-10V	0 V
-5 to +5V	-5V

So in this example, if you set the jumpers for 4-20mA, you will get 4mA output when the display is 50.00

- 4) When set, press the OK button.
- 5) Now the 100% O/P LED should flash
- 6) Set the display to the reading value where you want 100% Output, by using DIGIT and UP/DOWN buttons

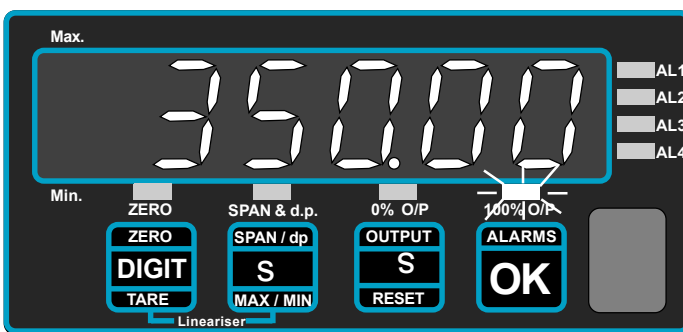

Jumpers on Analogue Board	100% gives
4-20mA	20mA
0-10V	10 V
-5 to +5V	+5V

So in this example, if you set the jumpers for 4-20mA you will get 20mA output when the display is 350.00

- 7) When set, press OK, to complete your adjustment of the analogue output scaling

**Please remember to set the lockout switch 'ON' to save your settings.**

## Serial Communications Output Option

You can have either an RS232 or an RS422 ASCII output at 1200 baud representing the meter's displayed value. You can have a continuous transmission of readings, or a single transmission on demand.

RS232 O/P on terminal 16 (data+) and terminal 18(common)

RS422 O/P on terminals 16 & 17(Data + and -) and 18 (common)

### String Format:

Data is made ASCII coded numerals, with embedded decimal point position if one has been set on the display, with a preceding - sign if the display is negative, with leading zero blanking, followed by a Carriage Return and a Line Feed.

So, for a displayed value of...

12345    the string will be <space><space><1><2><3><4><5><CR><LF>

-15.0    the string will be <space><space><-><1><5><.><0><CR><LF>

### Commands:

The data output port is activated by connecting to the ENABLE terminal.

For RS232, the ENABLE port must be held high at a 5V level for as long as serial data output is required, or, if only one string of data is needed, the ENABLE line must be held high until the transmission starts, after which it may be taken low again. The Sig- connection on terminal 17 may be used to provide the 5V level if an external source is not available

For RS422, the ENABLE port operates in reverse, so must be held low to enable transmission.

If you need a remote mimic display, the Model INTUITIVE-S is an ideal choice, being a 1/8 DIN meter directly compatible with this output format.

Also, we manufacture a range of Large Format remote displays having digit heights of 57mm, 102mm, 144mm, 200mm and 280mm. Ask us about the 1700 Series and the EasyReader Series.

## 8 Programme Memory Option

With the MEM-08 option, you can store up to 8 sets of configuration and calibration data. This is useful if you want to connect a number of different sensors, each with different calibration, to the meter, selected by rotary switch. Each memory location can have its own input/display calibration, alarm settings, and analogue O/P calibration. NB The linearisation facility is not available with this option.

Memory locations are addressed using an external switch. If you need up to 4 memories, you may use a simple rotary switch. If you need more than 4 memories you must use a BCD coded switch, as shown below.....

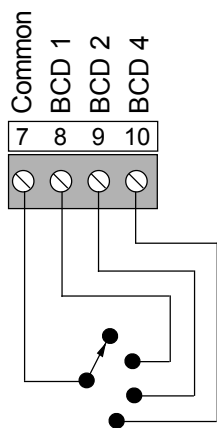

Simple rotary switch

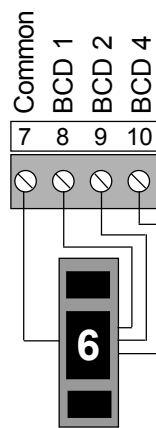

BCD coded switch

If you wish to use a rotary switch to select up to 8 memory locations, and to switch up to 8 two-wire signals, we make a 1/8 DIN rotary switch model SW2P8W-BCD for this purpose.

### Programming Notes:

Memory location 0 is a 'GLOBAL' programming location. When you programme location 0, the same data will be written to all the other memory locations as well. Therefore, always programme location 0 first. However if you switch off the switch next to the input connector, before programming location 0, this effect will not occur. The switch will then have to be set ON if you wish to access the other memories. If this feature is undesirable in your system, you should limit the number of programmes to 7 and arrange your switching to prevent location 0 from being accessed.(ie never have all BCD select lines disconnected from Common)

All programmes are stored in non-volatile EEPROM memory, which has a typical storage life of 10 years, and which does not rely on battery backup.

# Equipment Specifications

<b>Bezel size</b>	48mm high by 96 mm wide (1/8 DIN)
<b>Panel Cutout</b>	45 mm high by 92 mm wide
<b>Case Depth</b>	125 mm including connectors
<b>Weight</b>	300 grammes
<b>Case Material</b>	Black polycarbonate
<b>Connectors</b>	Detachable Screw Terminal connectors

<b>Power</b>	95-265 VAC or 11-30 VDC optional
<b>Burden</b>	8VA maximum

<b>Input Signals</b>	4-20mA 0-10mA 0-10VDC 1-5VDC Custom Ranges
<b>Input Resistance</b>	33 Ohms 33 Ohms 1 Meg 1 Meg Ask factory
<b>Accuracy</b>	+/-0.05% of range
<b>Span tempco</b>	50ppm/Degree Celsius
<b>Zero Tempco</b>	20ppm/Degree Celsius
<b>Excitation voltage</b>	24VDC +/- 20% rated at 50mA
<b>Filtering / smoothing</b>	Selectable time constants of 0 to 5 seconds.
<b>A/D conversion</b>	Dual slope 10 conversions per second. Resolution 1 in 63000 max. over full range
<b>Display update rate</b>	2 readings per second.
<b>Memory of total</b>	E2PROM with 10 year storage. No batteries required

## Plug-In Output Options

<b>Analogue O/P</b>	0-10VDC 4-20mA +/-5VDC
<b>Drive capacity</b>	>1K Ohms <500 Ohms >1 K Ohms
<b>Isolation</b>	250 VAC Optically isolated
<b>Linearity</b>	+/-0.02% of range, accuracy 0.1% of range
<b>Resolution</b>	12 bits
<b>Update rate</b>	10 per second (100 per second to special order)

<b>Alarm Relay O/P</b>	2 or 4 alarms SPST rated 5 Amperes at 250 VAC, resistive load. Selectable normally open or normally closed. Selectable energise or de-energise on trip.
------------------------	---

<b>ASCII Data O/P</b>	RS232 or RS422 ASCII Value of reading. 1200 baud.
<b>Format</b>	1 start bit, 8 data, no parity. <Measurement><CR>
<b>Isolation</b>	250 VAC optically isolated

# Record of Revisions/Changes

2 October 2001	Page 5 Switches changed Page 17 Analogue output board potentiometer note added.
31 July 2003	Declaration of Conformity amended
3 March 2004	Page 16 - changed reference from Grand Intuitive to Easy Reader

## Notes

# Declaration of Conformity

Declaration Reference : INTUITIVE  
Issue Date : 9 October 1998 revised 31 July 2003  
Products Covered : INTUITIVE series  
Title : DOC-INTUITIVE

This is to confirm that the Product covered by this declaration have been designed and manufactured to meet the limits of the following EMC Standard :

EN61326-1:1997

and has been designed to meet the applicable sections of the following safety standards

EN61010-1:2001

## Conditions

The meters are permitted a worst case error of 1% of A/D range during electro-magnetic disturbance, and must recover automatically when disturbance ceases without the need for human intervention, such as resetting, power-down etc.

The meters covered by this certificate must be installed in adherence to the following conditions :-

Signal cabling shall be routed separately to power carrying cabling (includes relay output wiring)  
All signal cabling shall be screened. The screen shall only be terminated to the power earth terminal

Declared as true and correct, for and on behalf of London Electronics Ltd.

Warren Court, Beds.

J.R.Lees Director