

London Electronics Limited

Thorncote Road, Near Sandy, Bedfordshire SG19 1PU
Tel +44(0)1767 626444 Fax +44(0)1767 626446
www.london-electronics.com help@london-electronics.com

Large digit counter / frequency / rate meter **FUSION-C 6 digit version**

Connection details, scaling and general information



Caution: There is a risk of electrical shock if this instrument is not properly installed



Caution: Risk of danger: Read the whole manual before you install this meter

Software version F00.14

1

Contents

Alarm board configuration	19
Alarm programming	20-25
Analogue output	17-18
Basic meter startup settings	10
Bootup routine	10
Brightness Adjustment	11
Button Functions	12-13
Connections	9
Connection Examples	33
Declaration of conformity	36
Dimensions	29
General Description	6
Input Configuration	15
Introduction	5
Keyboard timeout Delay	10
Language	10
Logic inputs	28
Modes and Scaling	14
Mounting and Installation	7
Notes	35
Option boards- installing	16
Ordering code	29
Record of revisions	31
Reverse/mirror/Heads-Up display	34
Serial output option	26-27
Specifications	30
Warnings	4
WEEE	32
Wiring Advice	8

Warnings

Please carefully read this manual and all warnings. Install the display ONLY when you are sure that you've covered all aspects.



Check that the model number and supply voltage suit your application before you install the display.



Connect the display according to current IEE regulations, IEC61010 & NFPA:70 National Electric Code in USA.



We designed this meter for Pollution-Degree 2 environments. It is sealed to IP65 NEMA4 all round for wall and suspension mounting versions with glands on the bottom surface.



Power supplies to this equipment must have anti-surge (T) fuses at 2A for 230V supply, 5A for 110V supply or 5A for DC supplies in the range 11-30VDC. A switch or circuit breaker, clearly marked as a disconnecting device, must be included close to the installation.



Don't touch any circuitry after you have connected the display, because there may be lethal voltages on the circuit board.



Only adjust on-board switches or connections with the power turned off



Make sure all screw terminals are tight before you switch the meter on.



Only clean the display's case with a soft damp cloth. Only lightly dampen with water. Do not use any other solvents.

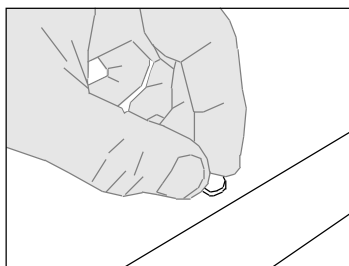

Rear case screws - please note

The rear panel is held in place with finger-screws, which only need to be gently tightened.

Do not use tools to tighten or loosen the screws, as this could cause damage to the internal threads.

**Safety FirstDon't assume anything..... Always double check.
If in doubt, ask someone who is QUALIFIED to assist you in the subject.**

Introduction

Please contact us if you need help, if you have a complaint, or if you have suggestions to help us improve our products or services.

If you contact us about a product you already have, please tell us the full model number and serial number, so that we can give you accurate and fast help.

This product has a 2 year warranty. We will put right or replace any meter which is faulty because of bad workmanship or materials. This warranty does not cover damage caused by misuse or accident.

IMPORTANT

If this equipment is important to your process, you may want to buy a spare to cover possible failure or accidental damage in the future.

This is because during factory shutdown periods, you may have to wait several weeks for an equivalent replacement, or we may have no stock at the time you urgently need it.

You may also need to pay extra carriage charges if you want a fast, guaranteed courier service. Warranty repairs or replacements are usually returned with a standard courier service.

We do not offer compensation for losses caused by failure of this instrument.

If you do not agree with these conditions, please return this item in unused, condition, in its original packaging and we will refund the purchase price, excluding any carriage paid.

We thought you'd prefer to know about possible delays and extra charges now, rather than during a panic. A spare unit could help to avoid these issues.

We always try to improve our products and services, so these may change over time. You should keep this manual safely, because future manuals, for new designs, may not describe this product accurately.

We believe these instructions are accurate, and that we have competently designed and manufactured the product, but please let us know if you find any errors.

General Description

The FUSION Series of displays accept industrial sensors to allow various physical measurements to be made, such as weight, temperature, pressure, humidity etc. Different models are available for different sensor types.

The main function of the FUSION series is to give a large numeric readout of the variable being monitored. You can choose from various digit sizes and formats. Most models include an excitation power output, to power the sensor directly.

Optional output modules are also available, to give alarm relay outputs, analogue output or digital communications, or any combination of these options.

Displays are programmed using front panel pushbuttons. The buttons may be locked with a switch. The buttons may also be wired remotely, so that you can make your settings from ground level.

These displays have two power supply options : 100-240 VAC or 11-30VDC

These units must be installed fully assembled, and must be installed according to local electrical installation rules. When properly installed, with glands on the lower surface, they provide ingress protection to IP65 / NEMA4X

Safety



Caution: There is a risk of electrical shock if this instrument is not properly installed



Caution: Risk of danger: Read the whole manual before you install this meter

Obey all safety warnings in this manual, and install the display according to local wiring and installation regulations. Failure to follow these guidelines may cause damage to the display, connected equipment, or may be harmful to personnel.

Any moving mechanical device controlled by this equipment must have suitable access guards to prevent injury to personnel if the meter should fail.

Mounting and Installation

Install your Fusion display according to local electrical regulations.

Mount it away from moving machinery, to minimise the chance of damage, and keep away from sources of heat, plastics solvents and electrical and magnetic noise, such as welding equipment, arc lighting, inductive machines etc.

The screws on the back of the display are necessary for sealing - do not omit any screws.

Do not overtighten screws - it is sufficient to finger-tighten them. In no circumstance use an electric screwdriver to remove or fit screws, or you will damage the case threads and sealing will be impaired.

Power cables and alarm relay cables should be routed separately to input signal, logic signal, serial data and analogue output cabling, to minimise the chances of electrical interference.

Wiring Advice

Only open the case when power has been removed.

This display uses internal detachable screw terminal connectors. Refer to the wiring diagram on the following page for the correct positioning of each wire. Each cable is fed through a compression gland for sealing. All glands must be sealed, unused glands must be plugged.

The conductors you use must be suitable for the meter's temperature, current and voltage rating, which is broadly described as follows:-

Cable Temperature Rating

All cables must be rated for operation up to 90C continuous.

Cable gauge

The connectors on this instrument can accept conductors up to 1.5mm² c.s.a. The minimum cross sectional area shall be 0.5mm²

Cable insulation voltage rating

Cables shall have an insulation voltage rating of at least 380V continuous.

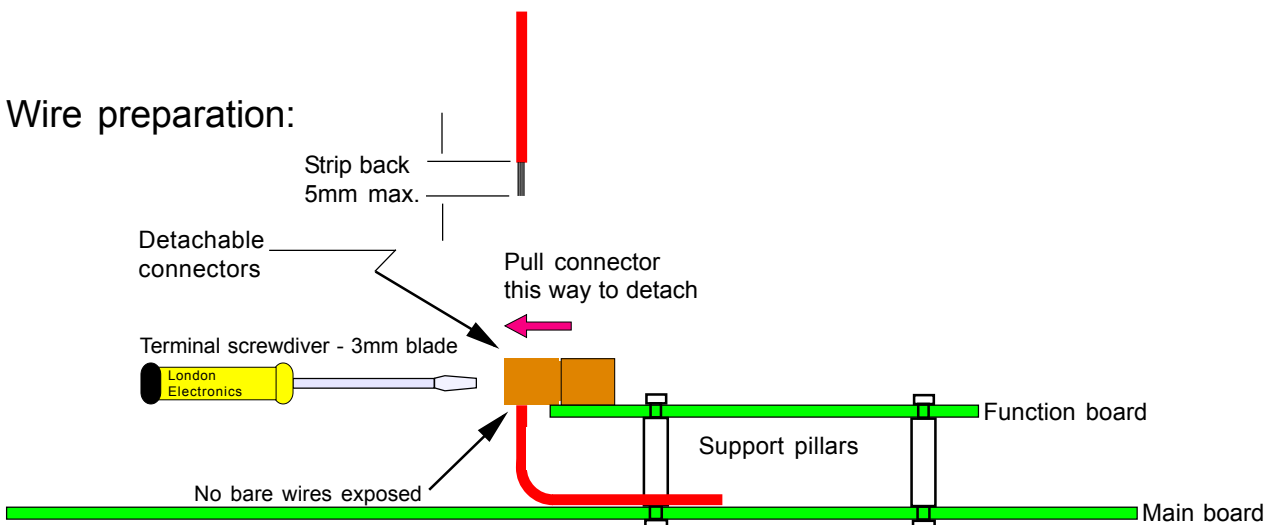

We recommend multi-strand wire, because it withstands vibration better than single strand cable. Pull the wire firmly after you make the connection to confirm it is tight.

Use screened cable for all signal and control wiring and connect the screen to earth at the destination end only. Route signal cabling away from power cabling and relay switching cabling, to avoid electrical noise interference.

Use a single, circular cable through each gland, diameter 4.5 to 6.5mm

Connections

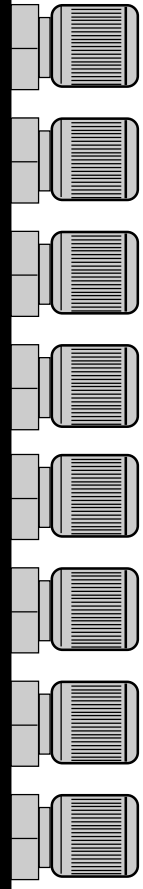
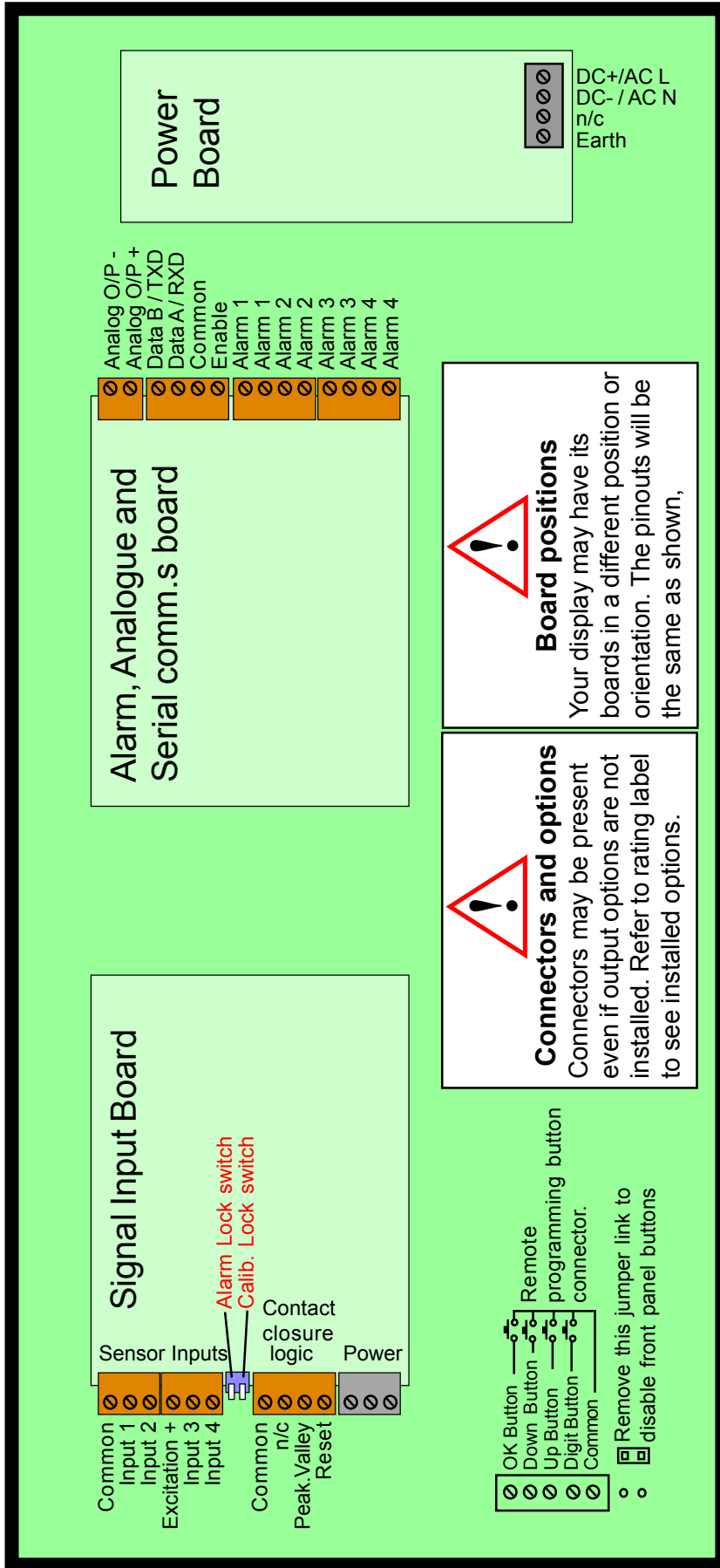

From 4 to 8 glands will be fitted, depending on output options installed.

Basic startup meter Settings

Lockout notes: Cal Lock switch = OFF when changing. Switch Cal Lock to ON after changing

Menu Language Choice

Press the two right hand buttons briefly. You will see the **User Interface** language, which you can change with the UP or DOWN buttons. Accept with OK

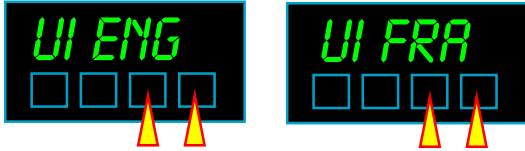

Next you will see ...

Meter Bootup routine

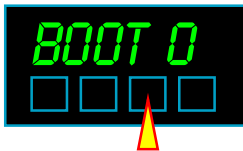

1. Activates all digit segments
2. Runs up and down brightness settings
3. Displays model number and installed options
4. Displays firmware version
5. Displays calibration audit number.
6. goes to meter mode



1. Activates all digit segments
2. Runs up and down brightness settings
3. Displays model number and installed options
4. goes to meter mode



1. Goes immediately to meter mode

When you switch the meter on, it can run through a summary list of software version number, installed options, calibration number etc.

You can choose from 3 lists of bootup information to be displayed, the less information you display, the sooner the meter will be available to operate.

Next you will see ...

Software de-bounce



You can enable a software debounce function for slow pulse rates, to limit pulses to once every 10 seconds. Select P.DB.0 to disable this function, or P.DB.1 to enable it.

Brightness Adjustment

Lockout notes: Cal Lock switch = ON when changing.

In normal operation, you can select from one of 8 brightness levels, to suit your local lighting conditions, or to match the brightness of several meters which may be from different batches or ages.









Press for 3 seconds, then press the down or up button to decrease or increase the brightness.

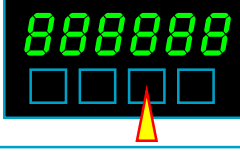



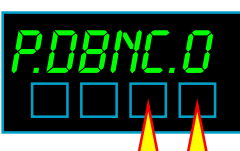

Press OK when set.

Your chosen brightness level will be saved in memory, so that the meter will return to the chosen brightness after power-off.

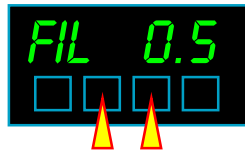
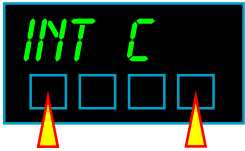
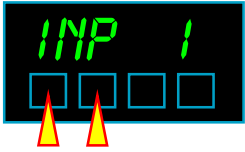
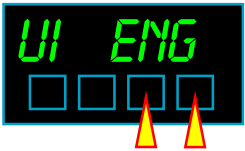
Button Functions- 'Quick-Step' - Page 1

Functions	Buttons	Conditions
Alarm Settings Press button briefly to view >3 seconds to change setpoint >5 seconds to change function		Can be viewed at any time. Alarm lockout OFF to change
Analogue Output Settings Press > 3 seconds to enter		Calibration lockout OFF
Brightness Press button for 3 seconds Change with UP/DOWN button. OK=Accept		Calibration lockout ON
Calibration Factor Press both buttons >3 secs, press OK 2x Change with UP/DOWN button. OK=Accept		Calibration lockout OFF
Calibration Offset Press both buttons >3 secs, press OK 3x Change with UP/DOWN button. OK=Accept		Calibration lockout OFF
Debounce - analogue filter Press both buttons >3 secs to enter input set. Change with UP/DOWN button. OK=Accept		Calibration lockout OFF
Debounce - digital filter Press both buttons briefly then press OK twice. Select 1 to enable, 0 to disable.		Calibration lockout OFF
Decimal Point position Press button 3 seconds, set during Scaling Change with UP/DOWN button. OK=Accept		Calibration lockout OFF

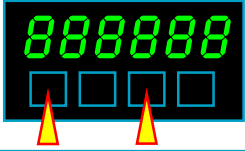
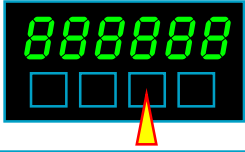
Button Functions- 'Quick-Step' - Page 2

Functions	Buttons	Conditions
<p>Filter time constant for Rate Press both buttons >3 secs Change with UP/DOWN button. OK=Accept</p>		Calibration lockout OFF
<p>Hardware & Software summary Press both buttons >3 secs</p>		Can be viewed at any time
<p>Input Configuration Press both buttons for 3 seconds. Change with UP/DOWN button. OK=Accept</p>		Calibration lockout OFF
<p>Language& Boot-up mode Press both buttons briefly Change with UP/DOWN button. OK=Accept</p>		Calibration lockout OFF
<p>Last digit round-up Press both buttons >3 secs, press OK once Change with UP/DOWN button. OK=Accept</p>		Calibration lockout OFF
<p>Menu timeout delay Press both buttons briefly, press OK 3x Change with UP/DOWN button. OK=Accept</p>		Calibration lockout OFF
<p>Mode and Scaling Press button for 3 seconds. Change with UP/DOWN button. OK=Accept</p>		Calibration lockout OFF
<p>Reset Peak & Valley memories Press buttons briefly</p>		Calibration lockout ON Link terminals 7,10 and 8
<p>Serial Comms setup Press both buttons briefly</p>		Calibration lockout OFF
<p>Reset display to 0 Press button briefly. Display shows 0.</p>		Calibration lockout ON and Link terminals 7 and 10
<p>Valley & Peak (Max. & Min.) Press button briefly, once for peak, next for valley.</p>		Calibration lockout ON Link terminals 7 and 9

Modes and Scaling

The INT-C2 has a number of useful operating modes. When you have chosen a mode, you can then scale the display. To select a mode, switch the lockout switch OFF and press the Set1 button for 3 seconds....

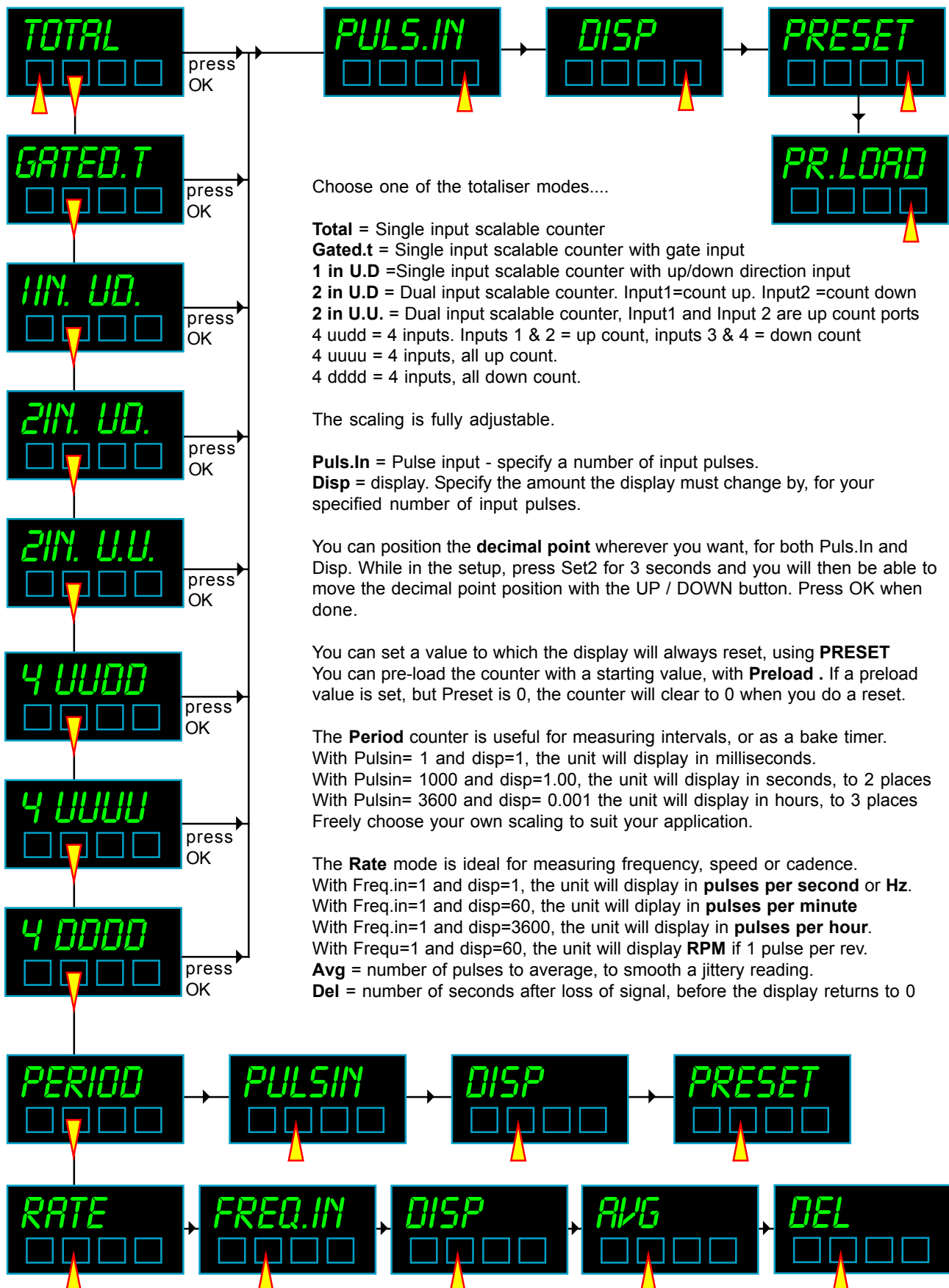

Input Configuration

You can configure the inputs, using the buttons, to accept AC, DC or low level inductive pulses. You can also choose whether to have a pull-down or pull-up resistor (for PNP, NPN or contact closure inputs) and whether to include de-bounce filtering, to minimise contact bounce effects. Each input can be configured independently. To configure the inputs, switch the lockout switch OFF and press Set1 and Set2 buttons together for 3 seconds...

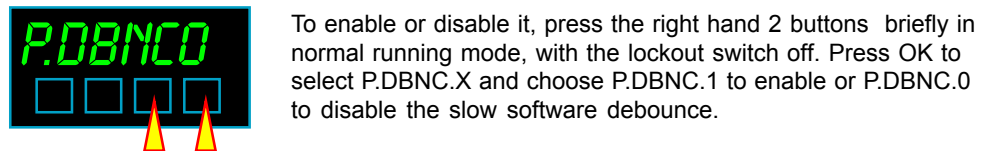
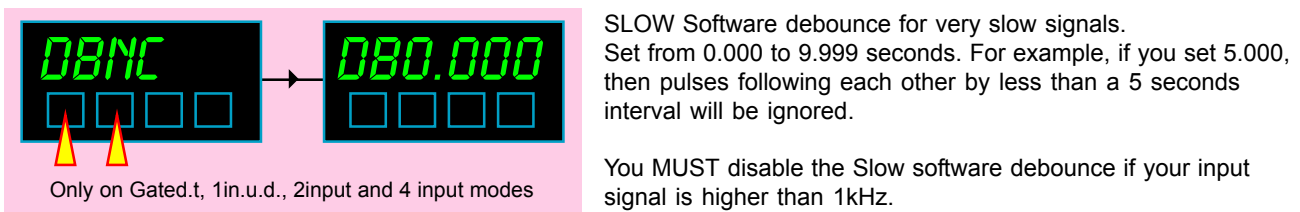
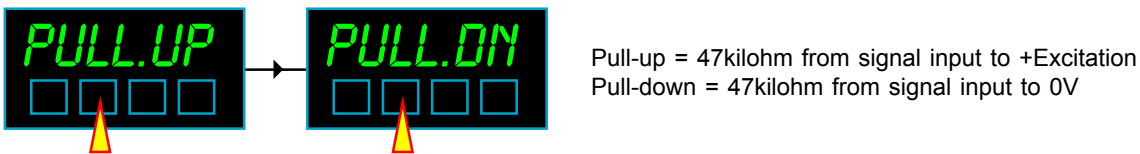
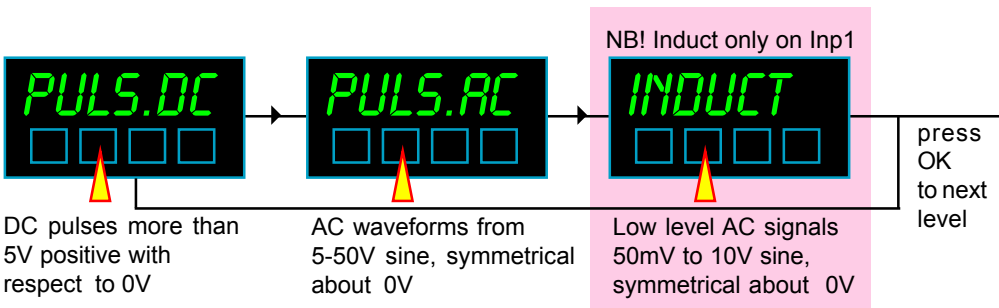
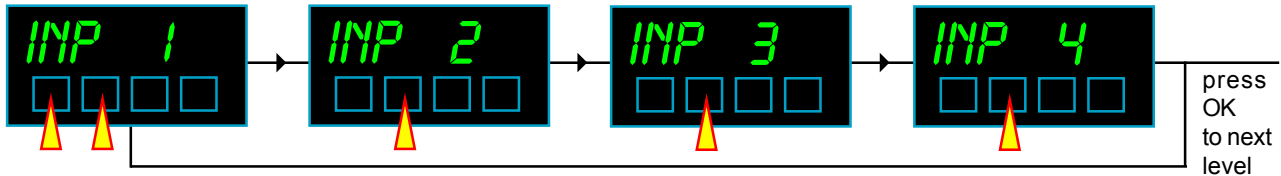

Signal Input type	Use these Settings			
NPN	PulsDC	Pull.Up	DBN.OFF	dbnc dbx.xxx
PNP	PulsDC	Pull.Dn	DBN.OFF	dbnc dbx.xxx
Contact closure	PulsDC	Pull.Up	DBN.ON	dbnc dbx.xxx
24V DC	PulsDC	Pull.Dn	DBN OFF	dbnc dbx.xxx
Passive Inductive pickup*	Induct	Pull.Dn	DBN.ON	dbnc dbx.xxx
AC voltage 5V up to 50V	PulsAC	PullDn	DBN.OFF	dbnc dbx.xxx

* Only available on input 1

Only on Gated.t, 1in.u.d., 2input and 4 input modes

How to install option boards



Warning:
Disconnect all power before exposing the rear of the meter

If you want to open your display to install or modify option boards, follow these steps...

- 1) Switch off power to the display.
- 2) Undo all screws on the rear of the case, remove the back panel.
- 3) The internal display board has positions for mounting the main board and the option board
- 4) The option board will either have 0, 2 or 4 relays, and can be fitted onto the connectors. It is secured by white plastic press-pillars. You can add an analogue output option and a serial output option to this option carrier board, or one of each, or neither.

The board assemblies will look something like this...

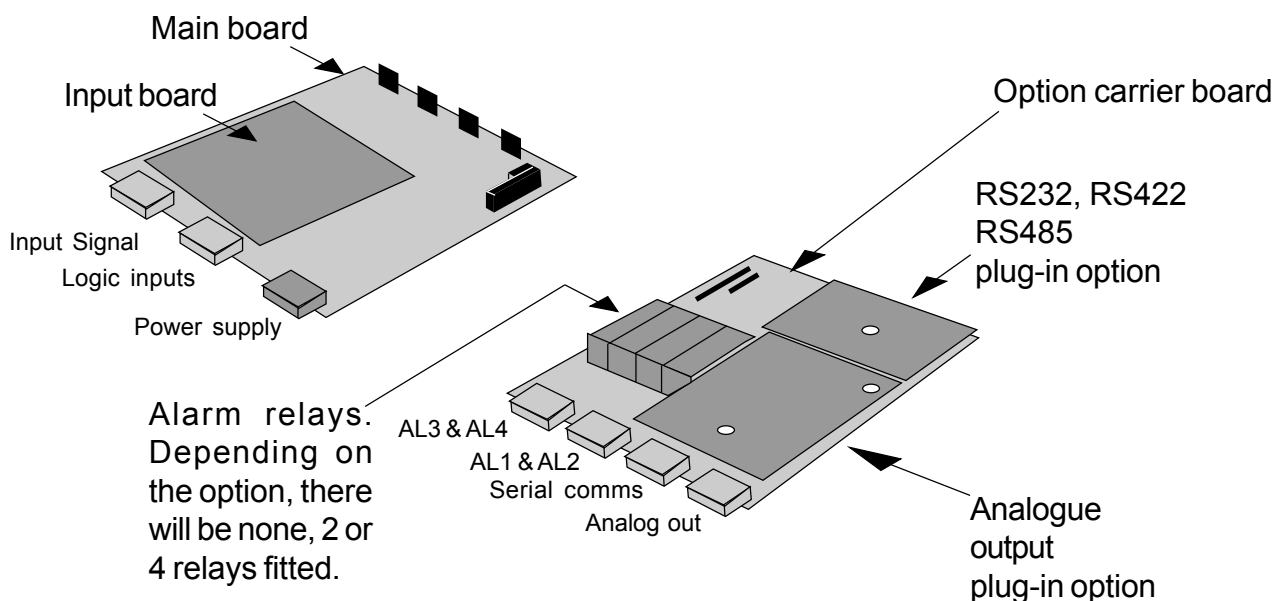

You must apply a firm force when fitting or removing these options.

Always be careful to connect the pins to sockets accurately. When reassembling, make sure option boards are firmly fixed to the upper option board. When the boards are installed, you can make connections via the cable glands - see manual for terminal identification. When wiring is complete, replace the back panel and re-fit all the screws - do not over-tighten.

Analogue Output - page 1



Warning:
Disconnect all power before exposing the rear of the meter



Warning:
Disconnect all cables from option board before adjusting

The analogue output board plugs onto the 0, 2 or 4 alarm upper option board.

It plugs onto a pair of connectors and is secured by two snap-pillars.

Check that the unit is set for voltage or current output, to suit your application.

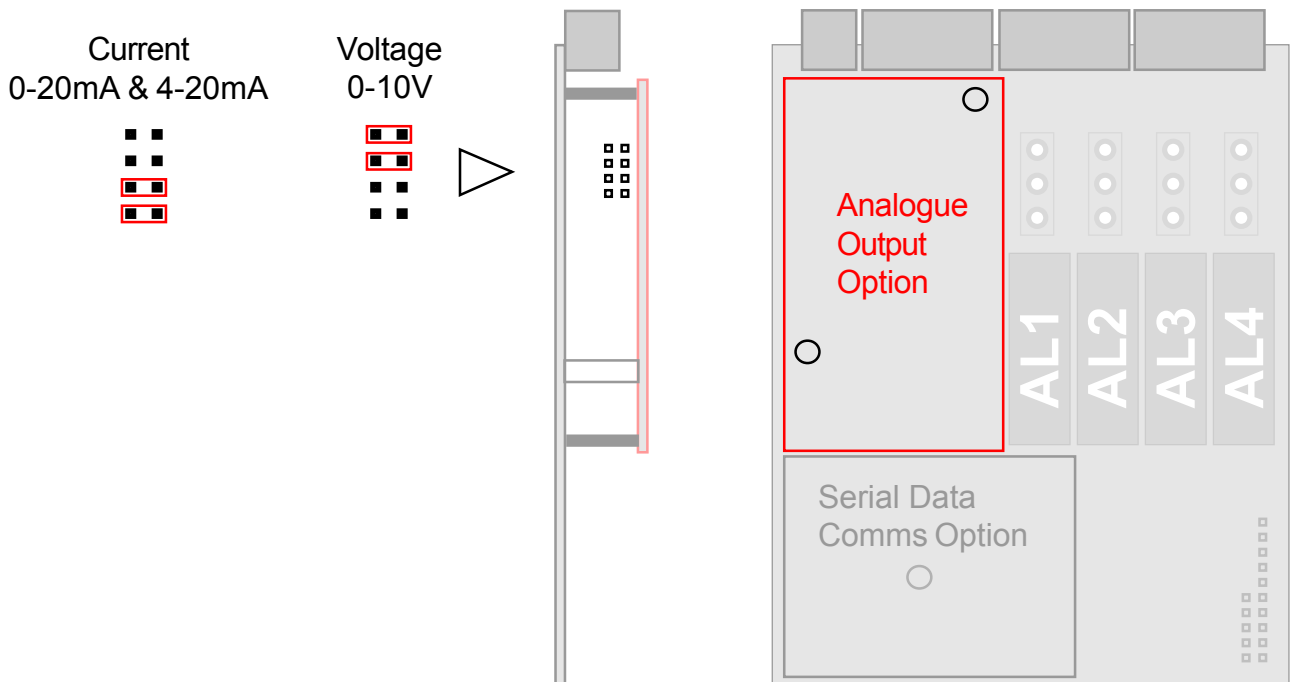

Re-assemble the meter, apply power and follow the Analogue Output Settings procedure on the next page.

You can set the analogue output to operate over a display range of your choice, to create 0-20mA, 4-20mA or 0-10V, fully isolated.

Please see the following page for a guide how to do this.

Handy Feature

You can tell if an analogue output is fitted to your meter, and if it has been set for voltage or current, by viewing the 'Summary' display.

To see this, press the two outer buttons of the display for 3 seconds. You will also see the summary when you first switch on your meter.

Analogue Output - page 2

Lockout notes: Cal Lock switch = OFF when changing. Switch Cal Lock to ON after changing

Your analogue output can cover 0-100% of its range over a display range which you can set.

For example, you might want 4-20mA output, for a display range of 500 to 1000.

You would press the Analogue O/P button for 3 seconds, and select 4-20mA

Then set 0% = 500

Then set 100% = 1000

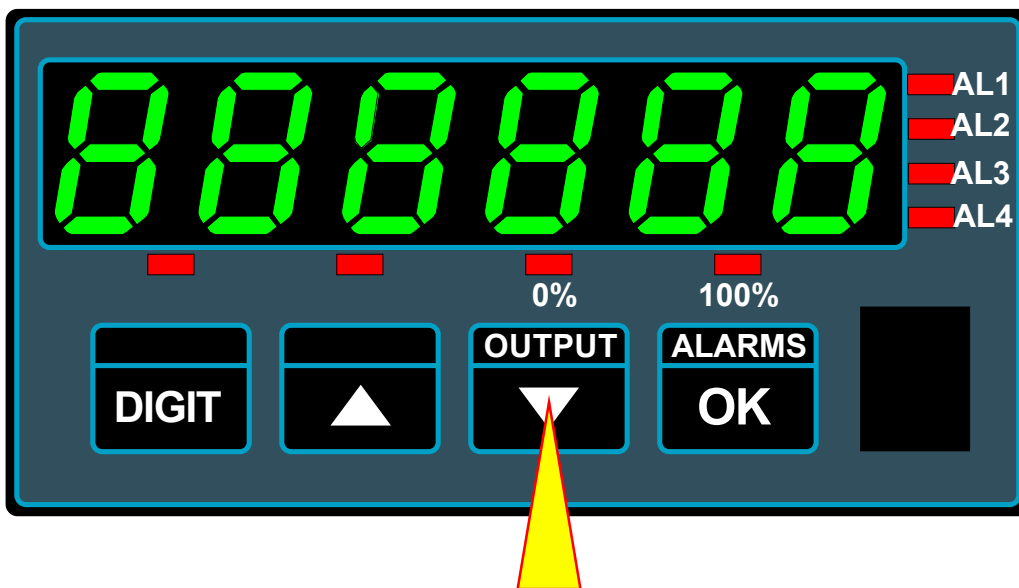

Press the OUTPUT button for 3 seconds. If an output board is fitted, the display will confirm this and confirm the range chosen by the jumpers on the previous page.

The 0% LED will flash. Select the Output range you want.

Use the **DIGIT**, ▲ and ▼ buttons to set the display value at which you want 0% analogue output.

Press **OK** when done.

The 100% LED will flash.

Use the **DIGIT**, ▲ and ▼ buttons to set the display value at which you want 100% analogue output.

Press **OK** when done.

When you have finished setting the meter, put the lockout switch in its ON position now, to prevent your settings from being changed.

Alarm Board Configuration

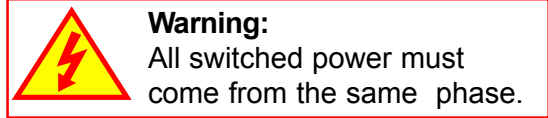
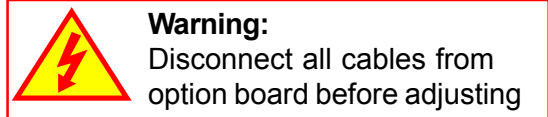
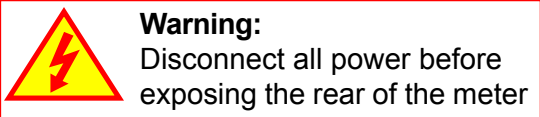

You can have 3 types of alarm board:-

- An alarm board with no relays, which will simply allow you to fit analogue and/or serial output options.
- An alarm board with 2 relays, to which you can also fit analogue and/or serial output options.
- An alarm board with 4 relays, to which you can also fit analogue and/or serial output options.

For failsafe operation (where contacts open on alarm or when power is lost to the meter) set the jumpers for OPEN CONTACTS as shown below, and DE-ENERGISE on alarm, in the alarm setup menu.

To access the alarm board, remove power from meter, including any power which might be on the alarm output board.

Look on the top and bottom surfaces of the case, near the rear. You will see two small screws, one on each surface. Remove both screws. Now, clip off the front bezel and slide the meter assembly carefully out via the front of the case.

The relay board plugs into the main board. Gently separate the two boards.

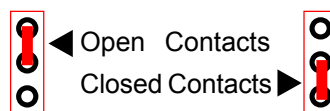
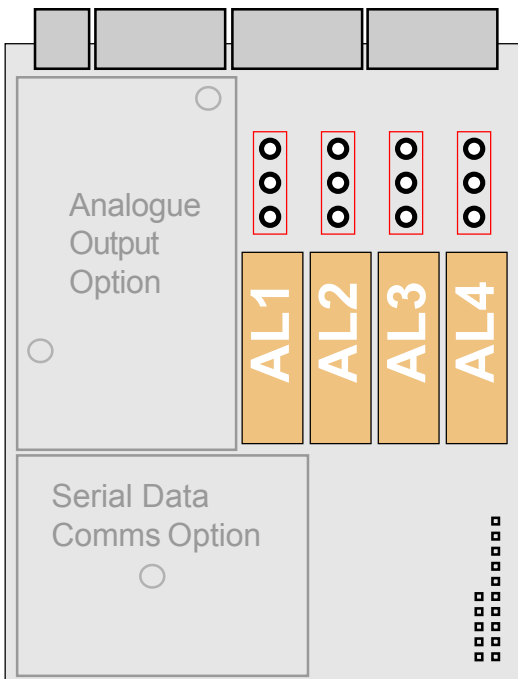

Select relay output contact status, when relays are de-energised (power removed from meter) by placing these jumpers. Each relay has a snubbing network to minimise contact sparking.

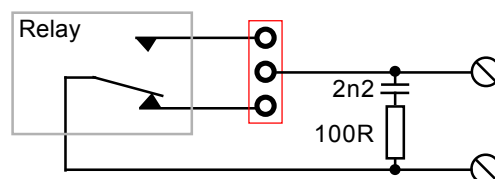

When you have set the jumpers, refit the board to the meter and carefully slide the assembly back into the case.

Fit the two small screws to the top and bottom surfaces of the case.

Alarm Programming

Lockout notes: Alarm Lock switch = OFF when changing. Switch Alarm Lock to ON after changing

Alarm lockout switch must be OFF. Press alarm button briefly to choose an alarm channel - look at the AL1, AL2, AL3 or AL4 leds to see which channel is selected.

Then press the alarm button for 3 seconds to show the Setpoint window - you can now edit the setpoint value with the DIGIT, UP and DOWN buttons. Press OK when done.



▲ 3 seconds, change setpoint only

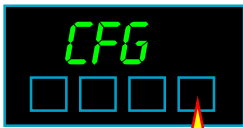

▲ 6 seconds, change alarm function and setpoint, or only 3 seconds if the alarm is currently set OFF

If you want to change the function of an alarm channel, keep your finger on the alarm button for a further 3 seconds after you see the Set.pt prompt, which will bring up the AL CFG (alarm configure) prompt.

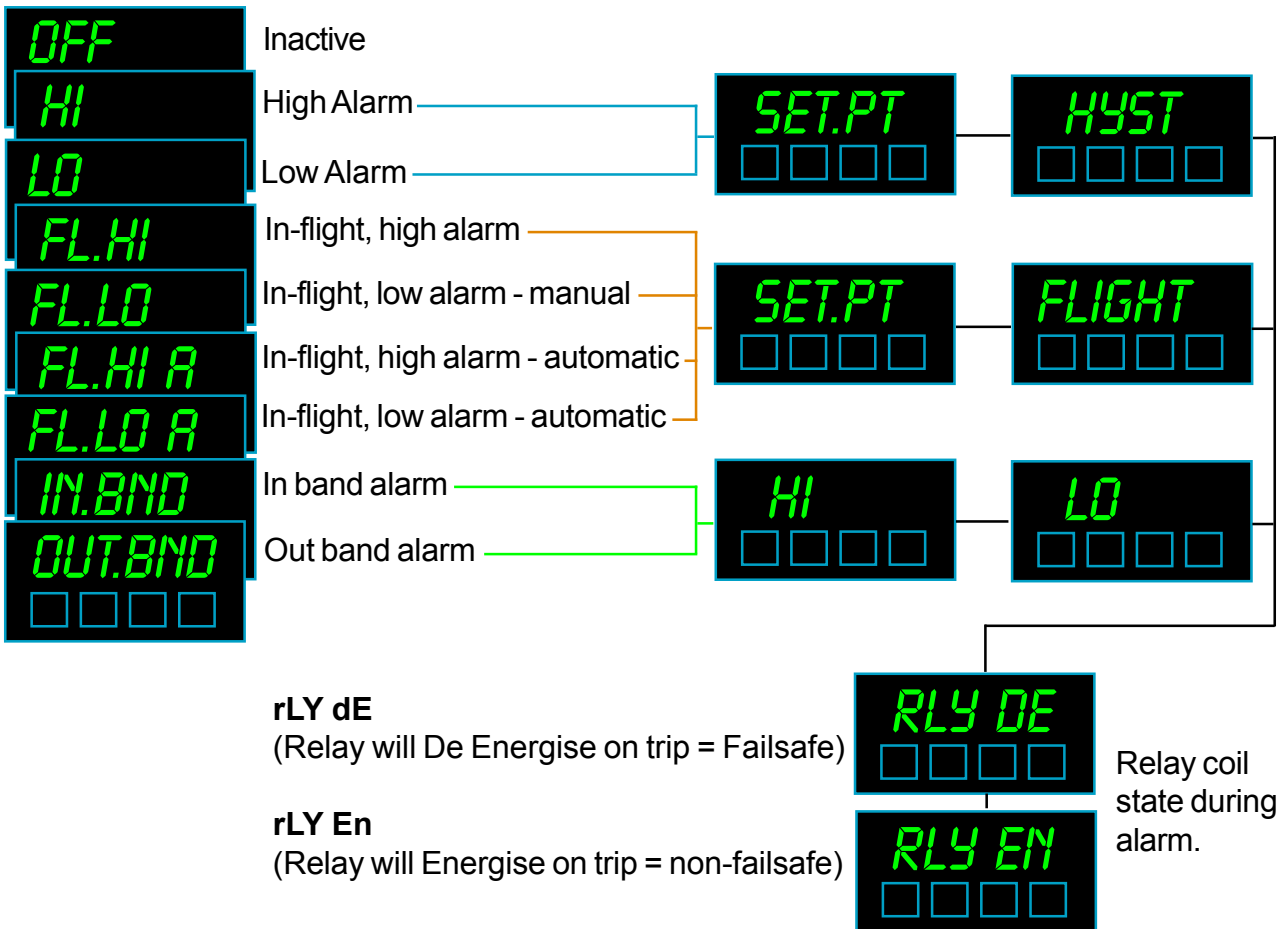

See the alarm board configuration page also, for details on selecting normally open or normally closed contact outputs.

See the following pages for more detailed descriptions of how each alarm mode operates. Remember to put the alarm lock switch ON when finished, to keep your settings safe.

Hi Alarm relay action, no Hysteresis

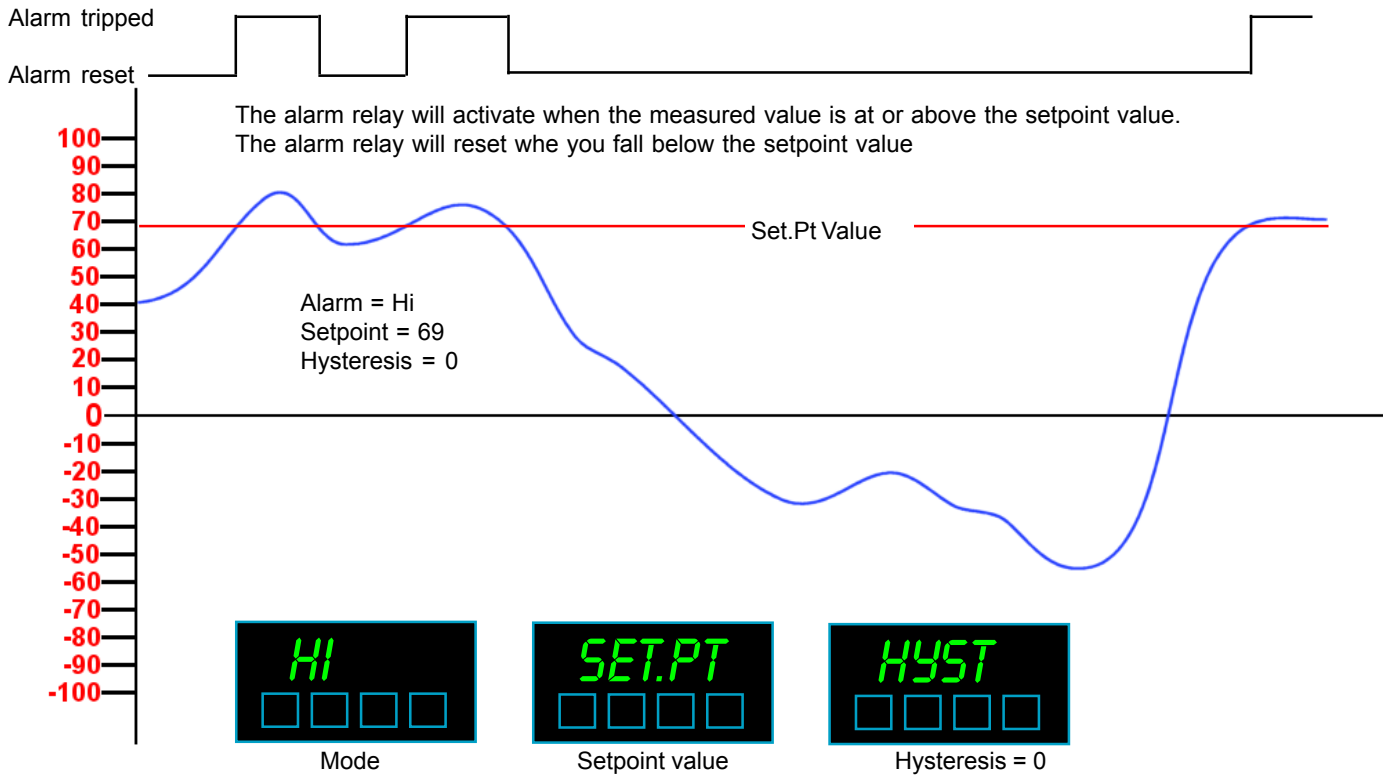

Hi Alarm relay action with Hysteresis

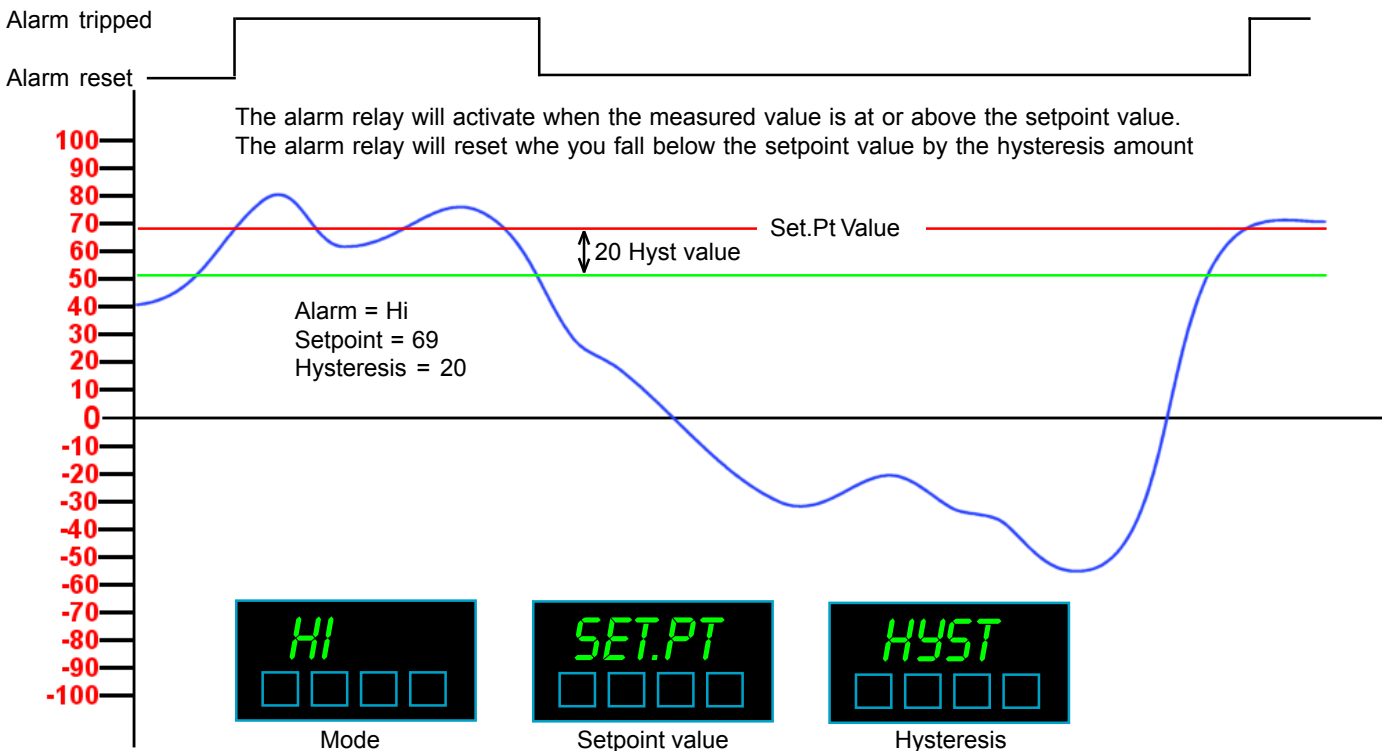

Lo Alarm relay action, no hysteresis

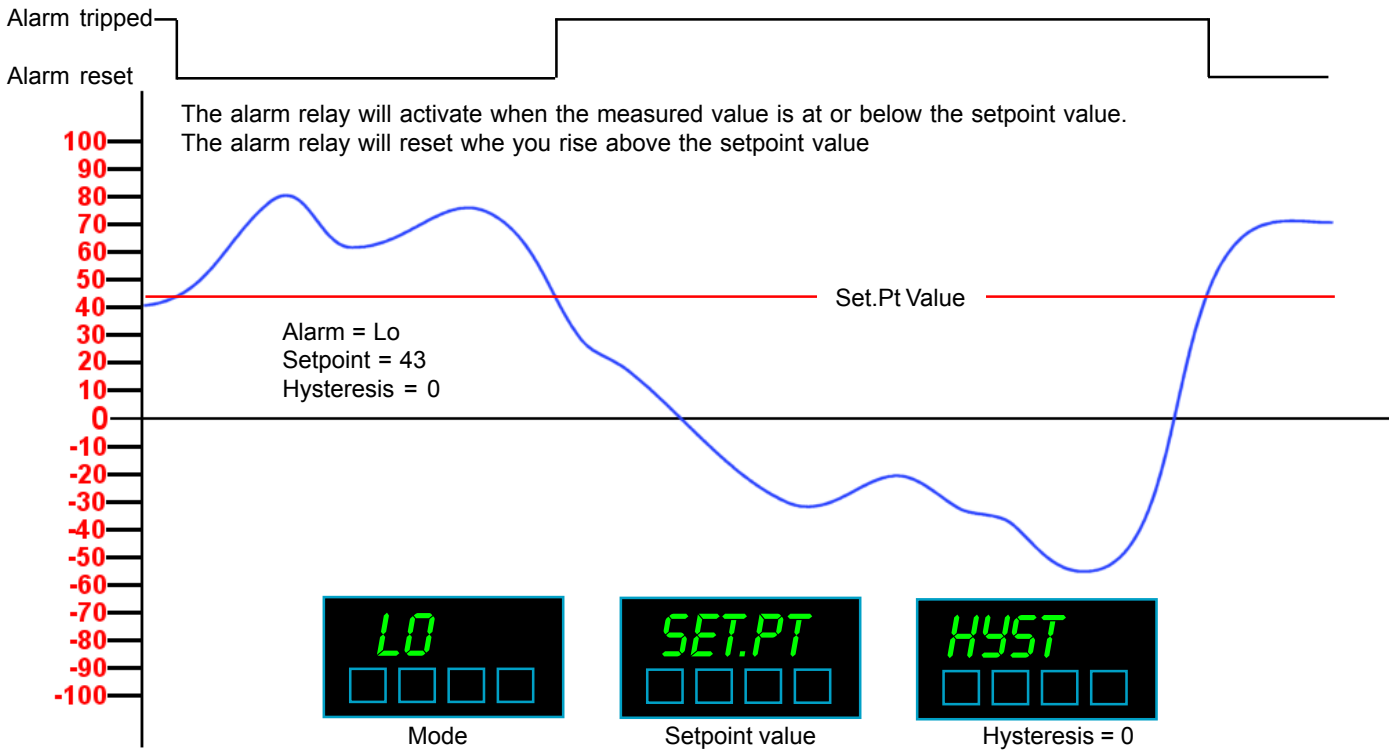

Lo Alarm relay action with Hysteresis

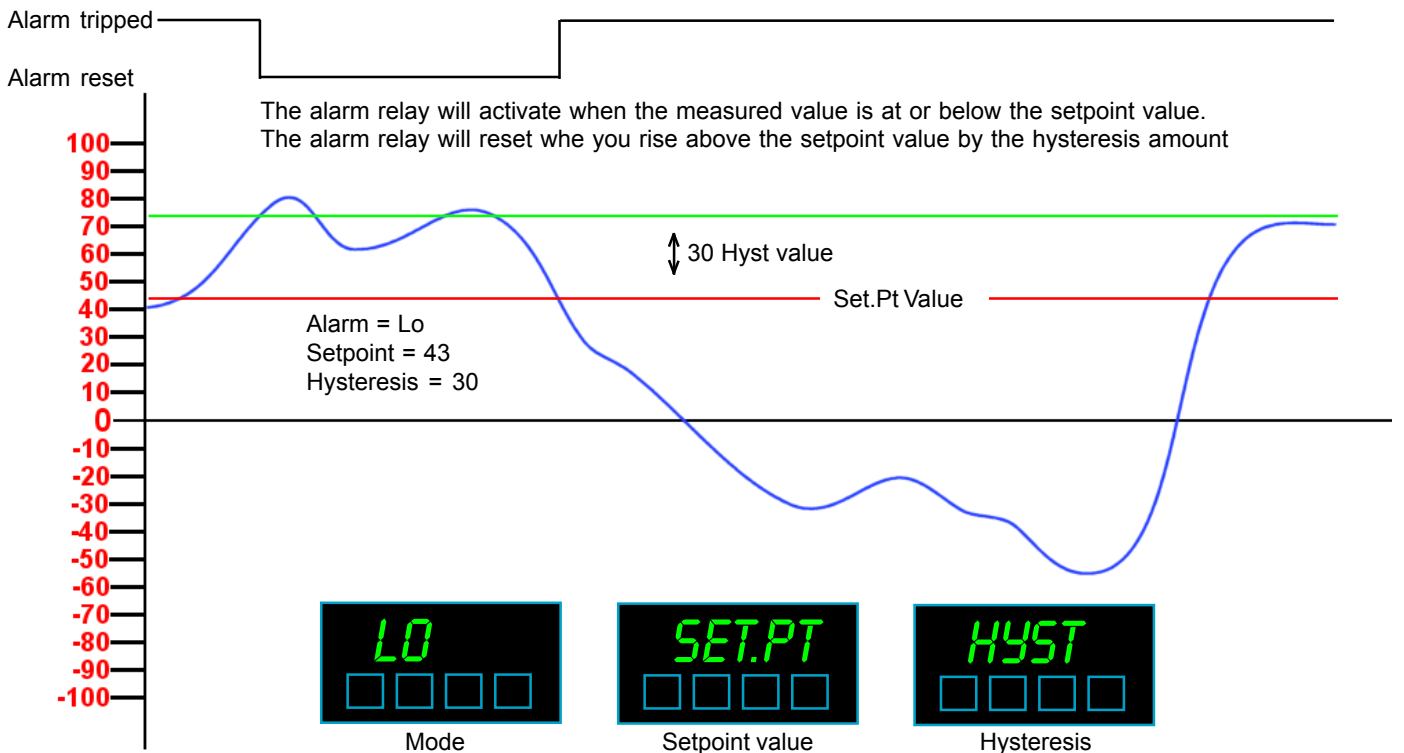

InFlight Hi Alarm relay

The In-Flight alarm modes are used in applications where you want to accurately fill one container from another.

If you were to simply close the shutoff valve when the weight reaches your desired amount, you would find that the weight is higher than you'd hoped for.

This is because some material is still in mid-flight when you send the alarm signal to shut the valve, and the valve will take some time to fully close.

The load measured on the loadcell platform will continue to increase after the alarm signal is sent to the shutoff valve.

The InFlight modes subtract or add this "In-Flight" amount from the setpoint to ensure that your final fill amount is as close as possible to your desired value.

In automatic mode, the unit will note the error after the first fill and try to correct for it on the next fill by moving the trip point by all the error amount on the 2nd fill and by half the subsequent error amount on each following fill. It will constantly monitor the error and correct by half that amount, to ensure a smooth trend towards accurate filling.

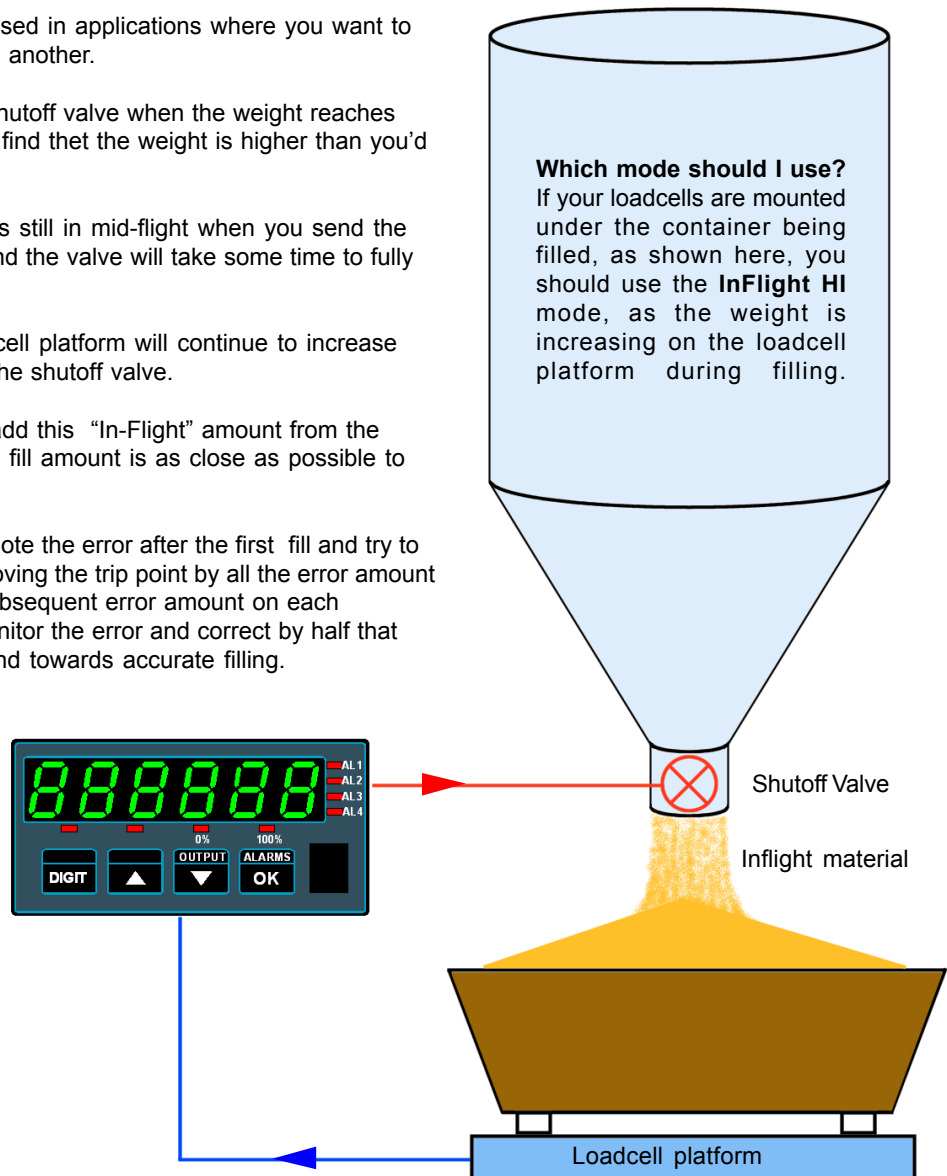

Manual or Automatic ?

You can set a manual value for the Inflight amount, if you know how much in-flight material will continue to fall into the container after the shutoff valve has been triggered, and if this value is likely to remain consistent from fill to fill.

If you don't know the inflight amount or if the material flow properties may change from batch to batch, you can use the automatic mode.

To set, press the alarm button until you illuminate the alarm LED channel you want to change. Press the alarm button again for around 6 seconds, you will see "Set.Pt" followed by "AL CFG". Use the Digit, UP/Down buttons and OK to set.

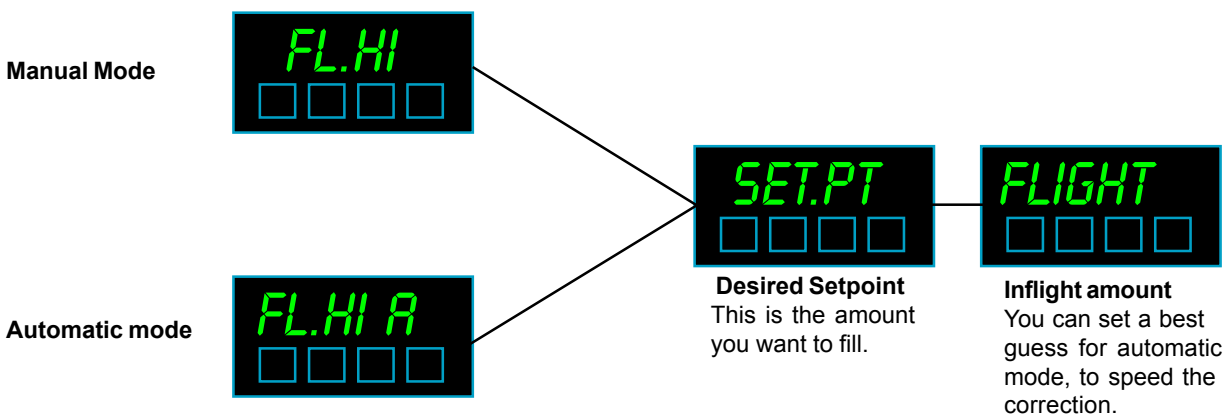

InFlight Lo Alarm relay

The In-Flight alarm modes are used in applications where you want to accurately fill one container from another.

If you were to simply close the shutoff valve when the weight reaches your desired amount, you would find that the weight is higher than you'd hoped for.

This is because some material is still in mid-flight when you send the alarm signal to shut the valve, and the valve will take some time to fully close.

The load measured on the loadcell platform will continue to increase after the alarm signal is sent to the shutoff valve.

The InFlight modes subtract or add this "In-Flight" amount from the setpoint to ensure that your final fill amount is as close as possible to your desired value.

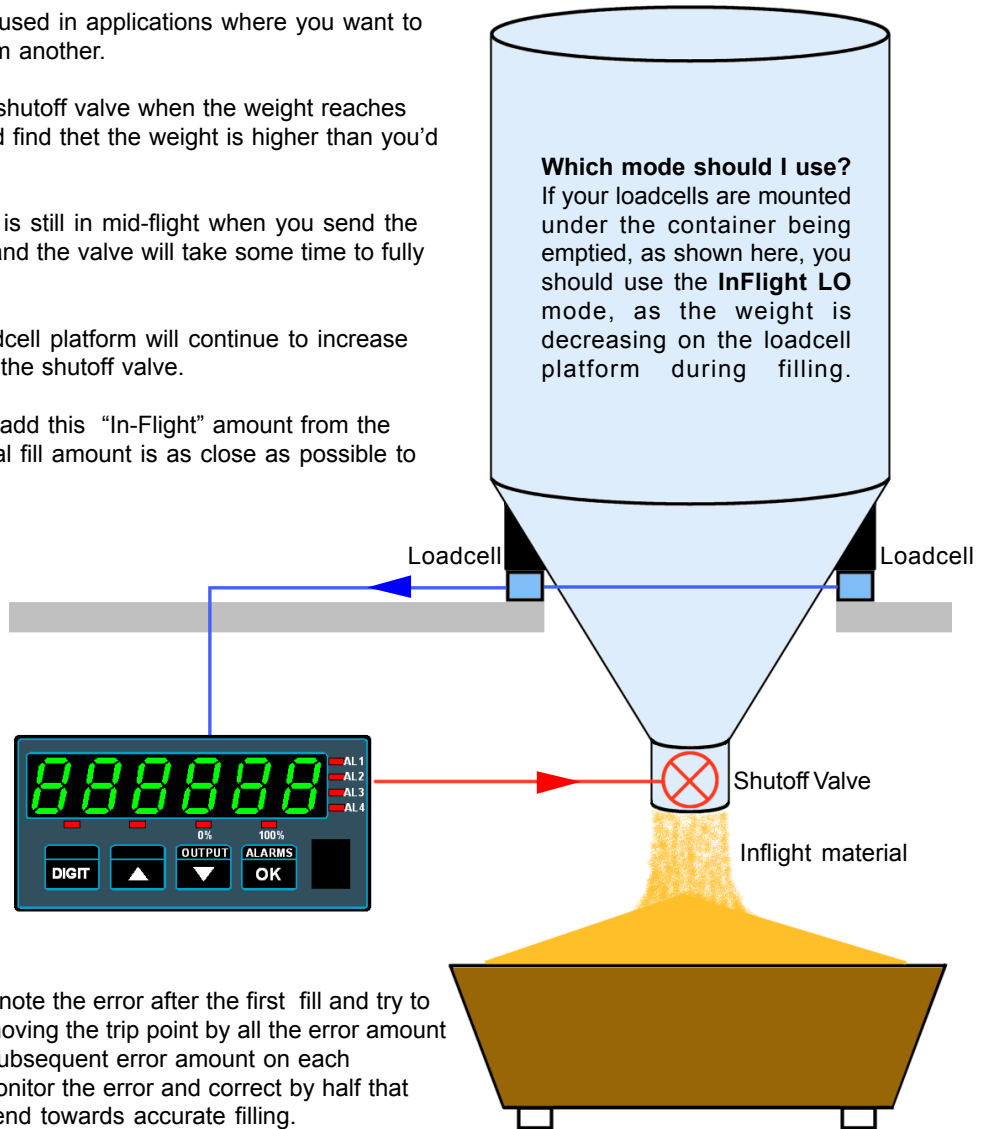

In automatic mode, the unit will note the error after the first fill and try to correct for it on the next fill by moving the trip point by all the error amount on the 2nd fill and by half the subsequent error amount on each following fill. It will constantly monitor the error and correct by half that amount, to ensure a smooth trend towards accurate filling.

Manual or Automatic ?

You can set a manual value for the Inflight amount, if you know how much in-flight material will continue to fall into the container after the shutoff valve has been triggered, and if this value is likely to remain consistent from fill to fill.

If you don't know the inflight amount or if the material flow properties may change from batch to batch, you can use the automatic mode.

To set, press the alarm button until you illuminate the alarm LED channel you want to change. Press the alarm button again for around 6 seconds, you will see "Set.Pt" followed by "AL CFG". Use the Digit, UP/Down buttons and OK to set.

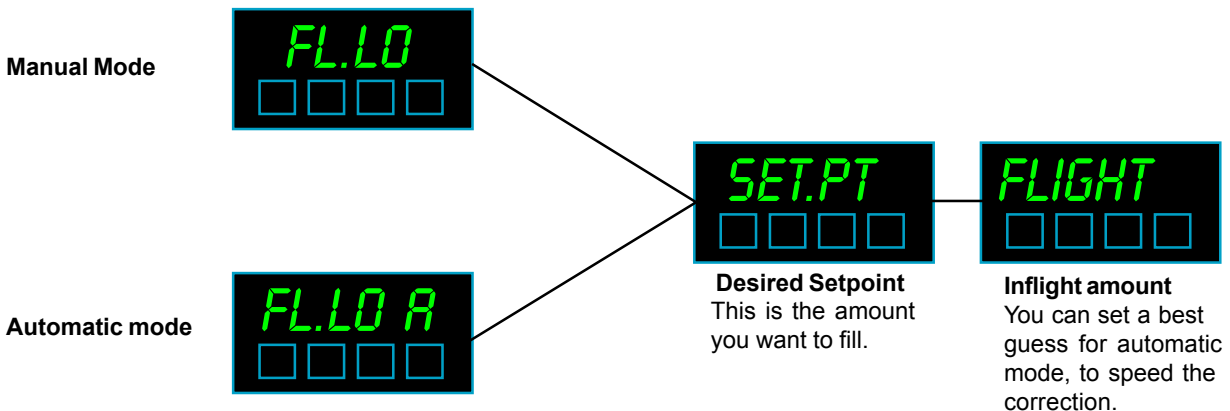

In-Band Alarm relay

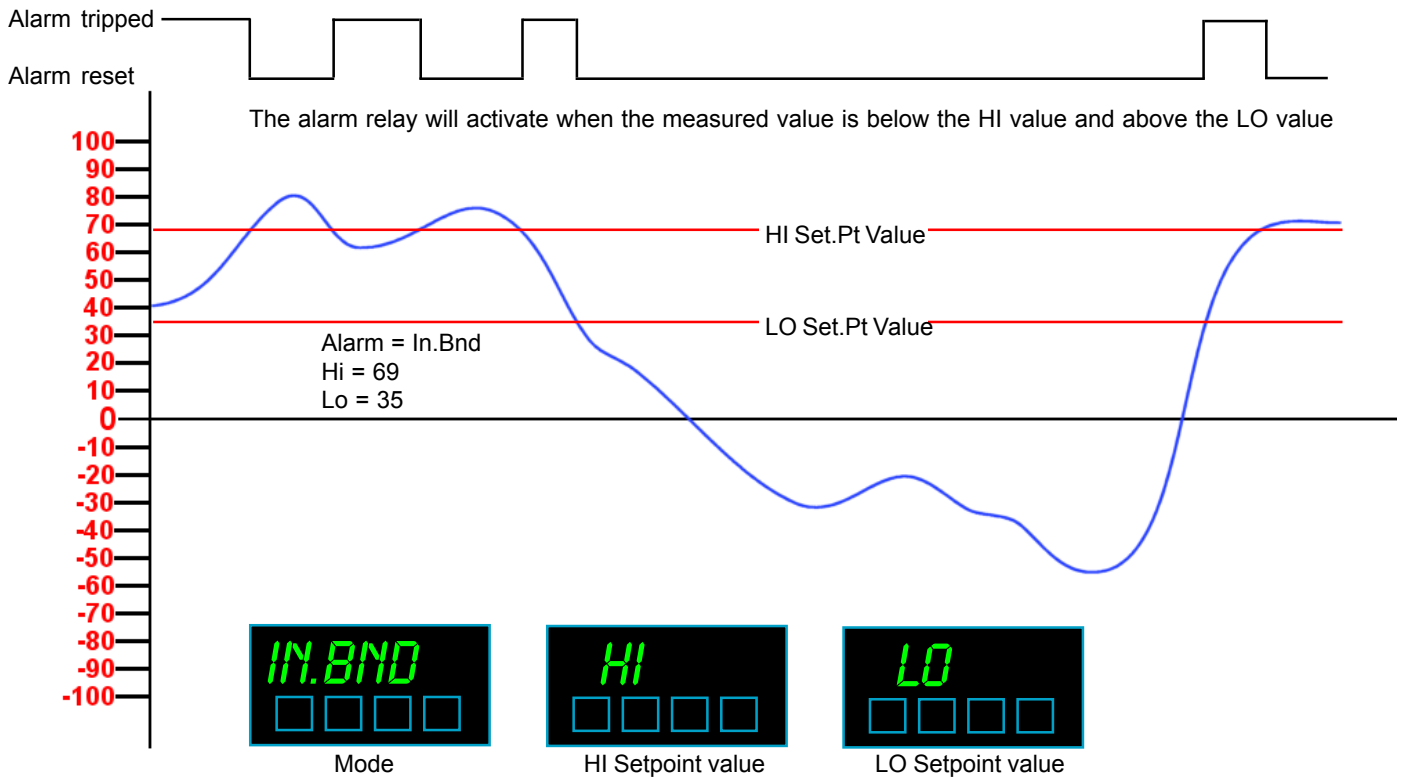

Out-Band Alarm relay

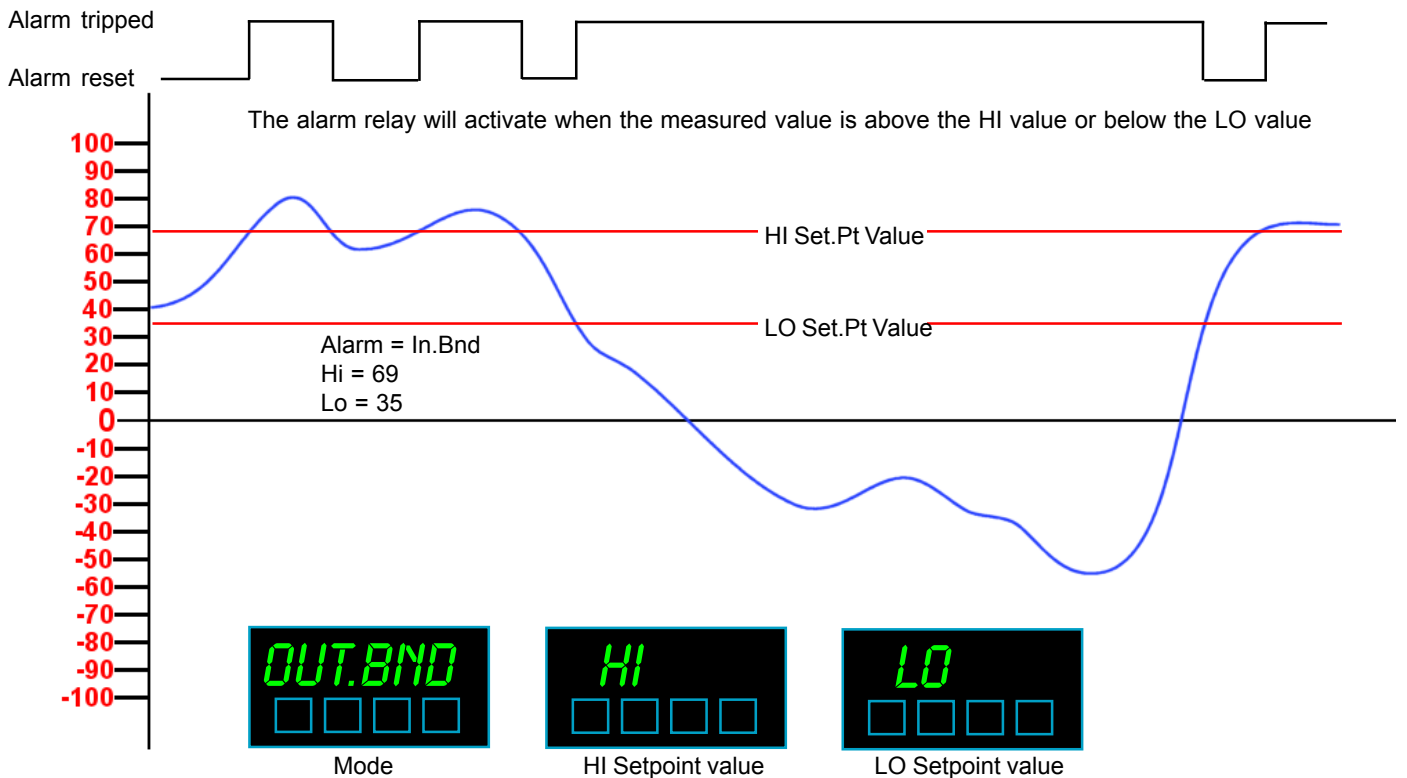

Serial Output - page 1

 **Warning:**
Disconnect all power before exposing the rear of the meter

 **Warning:**
Disconnect all cables from option board before adjusting

The serial output board plugs onto the 0, 2 or 4 alarm upper option board.

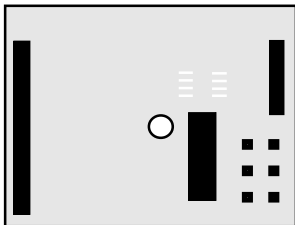

It plugs onto a pair of connectors and is secured by a snap-pillar.

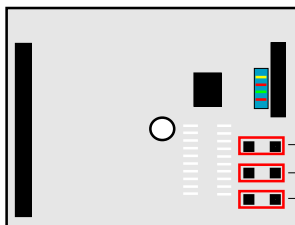

RS232 board
No jumpers needed



RS485 board

-  If fitted, connects 120 Ohm terminator
-  If fitted, sets a bias of +0V on Sig A
-  If fitted, sets a bias of +5V on Sig B

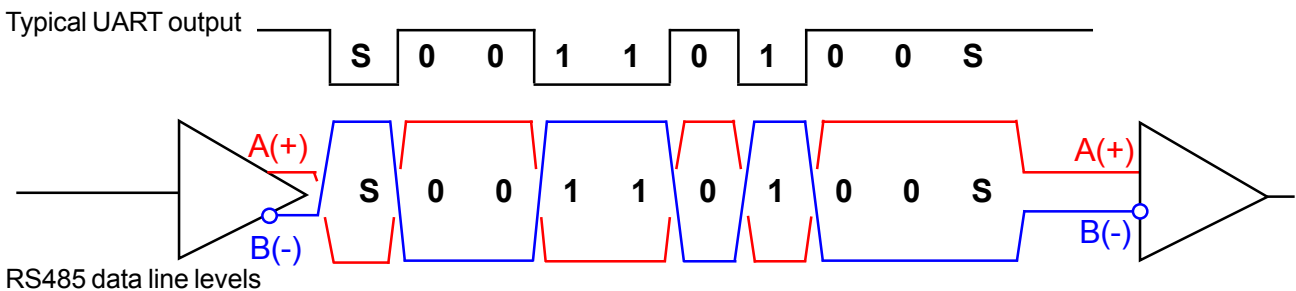
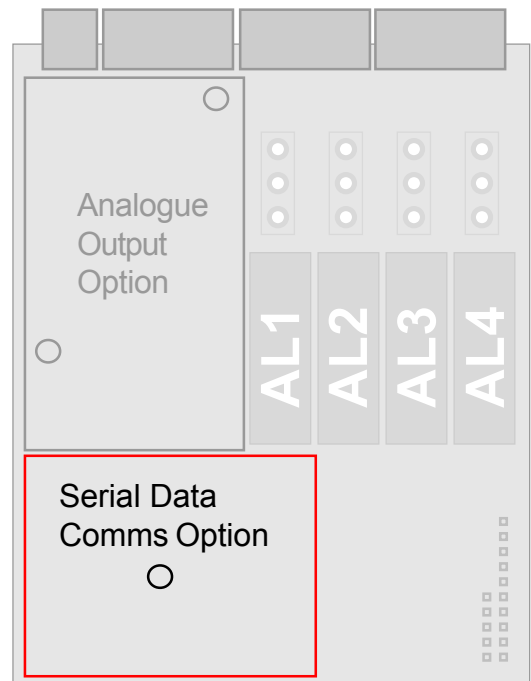

The 120 Ohm termination resistor should be fitted to only the last display on an RS485 data link, to improve noise immunity. A terminator should also be fitted on the sending device.

The bias jumpers are not normally fitted, but are available if your system needs biasing, to keep it in a valid idle state when data is not present.

Re-assemble the meter, apply power and follow the Serial Output Settings procedure on the next page.

Handy Feature

You can tell if a serial output is fitted to your meter by viewing the 'Summary' display. Press the two outer buttons of the display for 3 seconds. You will also see the summary when you first switch on your meter.

Serial Output - page 2

Lockout notes: Cal Lock switch = OFF when changing. Switch Cal Lock to ON after changing

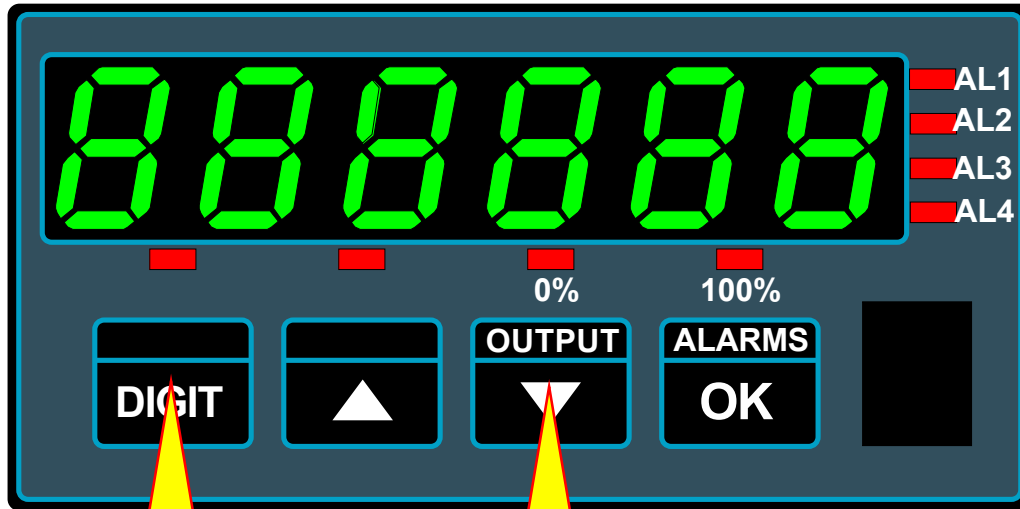

Briefly press together

Baud :- Select from 300,600,1200,2400,4800,9600,19200,38400, 57600,115200

dF = Data Format = 8n1, 7n1, 7E1, 7O1

Prot = Protocol = P1 (polled ASCII), P2 (Polled Modbus ASCII), C1 (Continuous), H1 (GPS)

Ad. = Address = 00 to FF

t.r = Reply Delay time in milliseconds 00 to 99

t.C = Character space timing in milliseconds 00 to 99

Protocol C1 – Continuous output

Meter sends: 8 characters<CR>

e.g.

20 20 20 20 20 2D 31 37 0D	(-17) decimal position = 0
20 20 20 20 2D 31 2E 36 0D	(-1.6) negative value
20 20 20 20 20 31 2E 38 0D	(+1.8) positive value
20 20 20 20 20 20 4F 52 0D	(OR) over range
20 20 20 20 20 20 55 52 0D	(UR) under range

Protocol H1 - GPS clock data format for use with our ASR-GPS

Protocol P1 – Polled ASCII

Controller sends: <STX> ADDRH:ADDRL r <ETX> e.g. 02 46 37 72 03 (to device F7)

Meter replies <STX> 8 characters <ETX>

e.g.

02 20 20 20 20 20 2D 31 37 03	(-17) decimal position = 0
02 20 20 20 20 2D 31 2E 36 03	(-1.6) negative value
02 20 20 20 20 20 31 2E 38 03	(+1.8) positive value
02 20 20 20 20 20 20 4F 52 03	(OR) over range
02 20 20 20 20 20 20 55 52 03	(UR) under range

Protocol P2 – Polled ASCII Modbus

When you have finished setting the meter, put the lockout switch in its ON position now, to prevent your settings from being changed.

Logic Inputs and extra button functions



Warning:
Disconnect all power before exposing the rear of the meter



Warning:
Logic inputs are NOT isolated from input signal

Lockout notes: Cal Lock switch must be ON to enable logic inputs.

Peak and Valley Detection (Maximum/Minimum Reading View)

The meter can store the lowest and highest reading values in memory. You can see these values if you press the MAX/MIN front panel button, or by using remote contact closure switches. The first press shows peak, with the upper left hand indicator bar lit (marked 'Max.'). The second press shows valley, with the lower left hand indicator lit (marked 'Min.'). The display returns to the running value after 2 or 3 seconds. To reset the memory, press the RESET button for more than 3 seconds while peak or valley is being displayed. Peak and Valley values are not stored if you switch the meter off.

How to use the MAX/MIN button to view Peak or Valley

- 1) Link terminal 7 to terminal 9
- 2) Set lockout switch 'ON'
- 3) Press UP arrow key (MAX/MIN) for peak, valley, normal

Remote contact closure viewing of Peak/Valley

- 1) Connect a normally-open contact closure switch between terminals 7 and 9
- 2) Set the calibration lockout switch 'ON'

Reset Command

The reset command clears any stored peak or valley data, any tared offsets and any in-flight compensation data. It may be accessed either from the front panel or by external contact closure command.

Front Panel key reset command

- 1) Link terminal 7 to terminal 10 (not necessary if MEM-08 option fitted)
- 2) Set calibration lockout switch 'ON'
- 3) Press Down Arrow key to reset display.

For Tare reset, you must press the Tare button AND the Reset button together.

For Peak/Valley reset, you must activate the reset key while a peak or valley value is being displayed.

Remote contact closure resetting

- 1) Connect a normally-open contact closure switch between terminals 7 and 10
- 2) Set calibration lockout switch 3 'ON'

Calibration Counter / Tamper detector

An internal totaliser counts each calibration. The 'CAL XXX' value appears for a second or two after you switch the meter on. The number starts at 00 and can go up to FFF. It counts all changes made to the meter's calibration. It stores the total in non-volatile memory which can't be reset, so is useful for keeping track of the meter's calibration history. You can ask the meter to repeat its summary at any time if you press the two outer buttons for 3 seconds.

Equipment Specifications

Case Depth	75 mm including connectors		
Case Material	Black uPVC		
Connectors	Detachable Screw Terminal connectors		
Environmental	Storage Temperature range -20 to +70C, non condensing Operating temperature range 0 to 50C, non condensing Sealed IP65 all round when glands are mounted on lower surface		
Power Burden	100-240 VAC, 45 to 60Hz or 11-30 VDC optional 50VA maximum		
Input Signals (4x)	Contact closures, with debounce NPN and PNP proximity sensors (47kilohm pullup/down) 24V logic pulses from PLCs AC tachometer inputs 100mV passive Inductance pickup (on Input 1 only)		
Frequency Range	0-40,000 Hz (0-100,000Hz on Rate only)		
Accuracy	+/-0.05% of range, quartz crystal reference		
Span tempco	20 ppm/Degree Celsius		
Excitation voltage	24VDC nominal rated at 60mA, to power sensors		
Averaging / smoothing	Selectable averaging time constant of 0 to 25 seconds.		
Memory	Totals and settings saved in 10 year non-volatile memory.		
Display update rate	3 readings per second.		
Display Range (max)	-199999 to 999999		
Plug-In Output Options			
Analogue O/P	0-10VDC	0-20mA	4-20mA
Drive capacity	>1K Ohms	<500 Ohms	<500 Ohms
Isolation	250 VAC Optically isolated		
Accuracy	+/-0.1% range, +/-10mV for ANV, +/-10uA for ANI, 50ppm/C stab.		
Linearity	+/-0.02% of range		
Resolution	better than 0.2mV for 10v, 0.4uA for 20mA range		
Scaling	Fully adjustable, direct or inverse		
Alarm Relay O/P	2 or 4 alarms SPST rated 2 Amperes at 250 VAC, resistive load. All relays must switch power from the same phase. Selectable normally open or normally closed by on-board switches. Selectable energise or de-energise on trip by menu Independant hysteresis on each alarm relay.		
ASCII Data O/P	RS232 or RS485 ASCII Value of reading.		
Format	1 start bit, 8 data, no parity. <Measurement><CR>		
Isolation	250 VAC optically isolated		

Record of revisions

1 May 2007	INT-L Released with F00.001 software
22 May 2007	Added RS485 logic level diagram
22 August 2007	Added Zener barrier application notes.
2 October 2007	F00.006 software. Linearisation added. Inflight compensation and band alarms added. Brightness setting added, Menu timeout delay added.
6 May 2008	Added 'General Description' page. Added power frequency spec. Mounting & Installation page added. Wiring Advice page added
27 May 2008	Added UL label sample to front page. Added ClassII connection details.
26 June 2008	Added Bootup option menu
31 Oct 2008	Added Reverse menu, software debounce in Version F00.12 software
21 Nov 2008	Version 14 software released, upgrading version 12 (no version 13). Corrects reset bug on totaliser and variable brightness bug.

Waste Electrical and Electronic Equipment (WEEE)

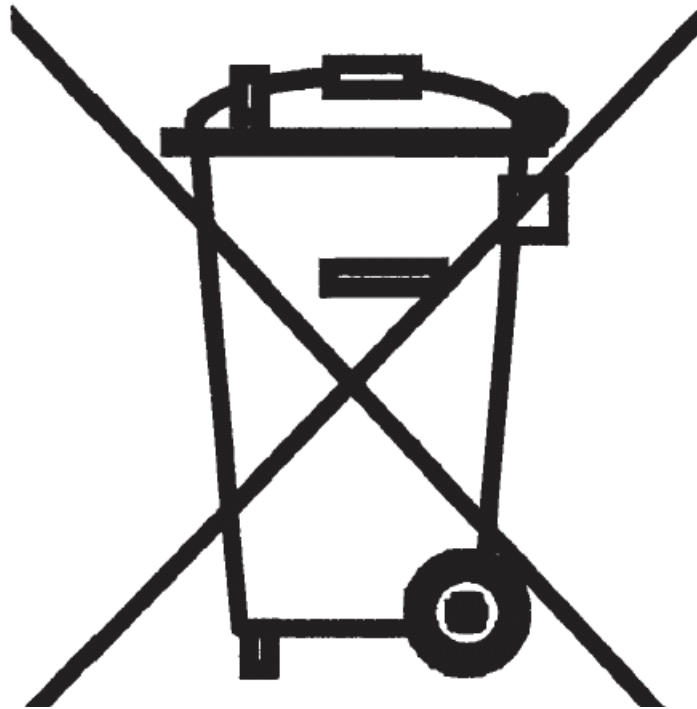

In Europe, this equipment must be disposed of in accordance with European Parliamentary Directive 2002/96/EC

This directive encourages recycling and the reduction of waste materials in the environment.

This means it must be sent to an approved recycling plant if you want to dispose of it.

It must not be thrown away in general rubbish.

If you are unable to dispose of this item locally, you may send it to us for recycling.

Conditions:

1. We will only accept items of our manufacture.
2. You must pay for the transport of the goods to us.
3. We will only accept items if they include a signed declaration by an authorised person in your organisation, stating that :-
 - i. The item is safe to handle and has no contaminants which may be harmful to health.
 - ii. You wish us to dispose of or destroy the item(s)

Connection Examples

NPN or PNP Sensor

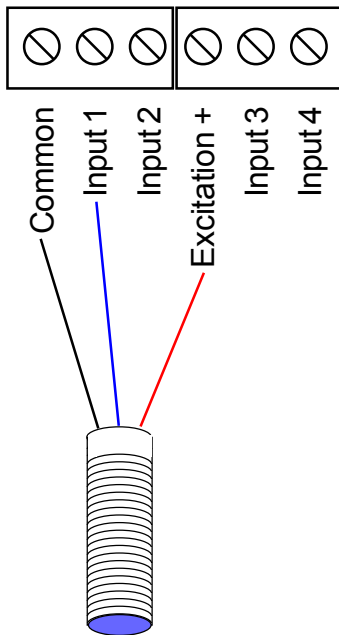

Contact Closure

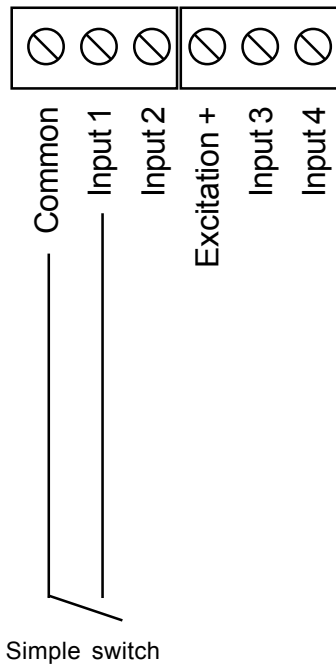

Up/Down count NPN

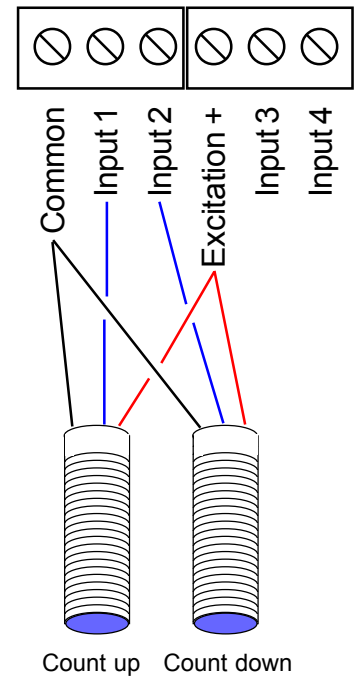

The logic input terminals, for RESET and PEAK/VALLEY, must **only** be connected to contact closures.

Do not connect voltages to the logic input terminals or you will damage the microprocessor.

Reverse/Mirror/Heads-Up display

Your Fusion display can be 'mirror-imaged' to allow it to be viewed as a reflection in a rear-view mirror, windscreen or other reflective surface.

This can be useful for creating 'heads-up' displays, for some test installations where the display will be viewed in a mirror, as a display for drivers reversing large vehicles, etc.

Reverse / Mirror display

Press both buttons briefly, press OK 5x

Change with UP/DOWN button. OK=Accept



Calibration lockout OFF

Choose Rev.0 for normal display

Choose Rev.1 for reflected display

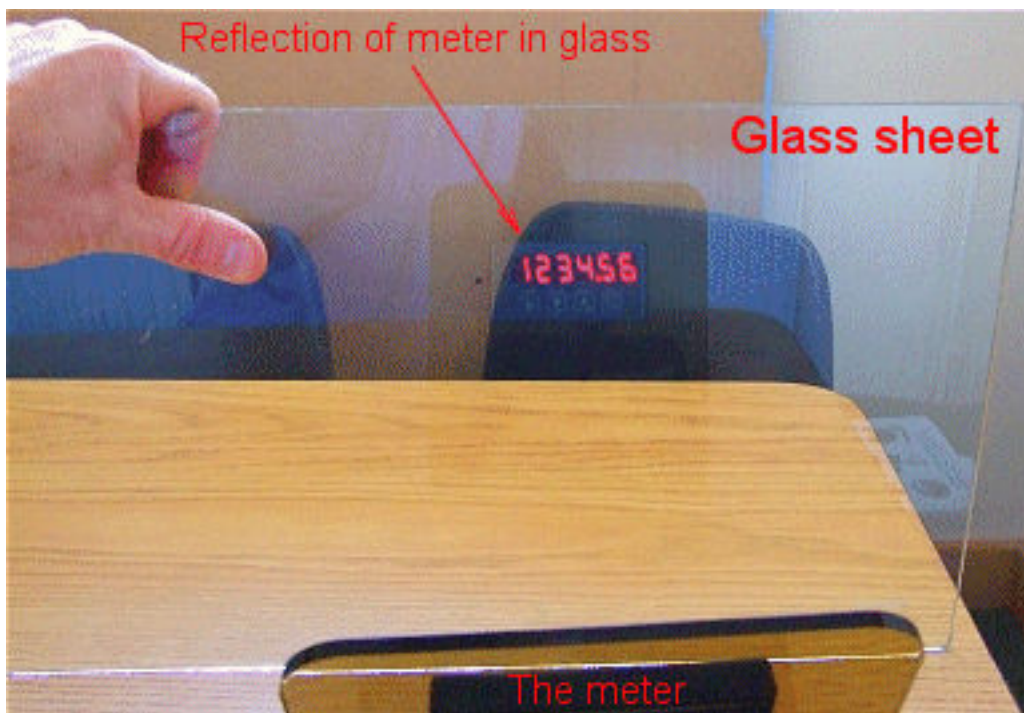

Notes

Declaration of Conformity

Declaration Reference : INTUITIVE Mk2
Issue Date : 30 April 2007
Products Covered : INTUITIVE Mk2 series
Title : DOC-INTUITIVE2

This is to confirm that the Product covered by this declaration have been designed and manufactured to meet the limits of the following EMC Standard :

EN61326-1:1997

and has been designed to meet the applicable sections of the following safety standards

EN61010-1:2001

Conditions

The meters are permitted a worst case error of 1% of A/D range during electro-magnetic disturbance, and must recover automatically when disturbance ceases without the need for human intervention, such as resetting, power-down etc.

The meters covered by this certificate must be installed in adherence to the following conditions :-

Signal cabling shall be routed separately to power carrying cabling (includes relay output wiring)
All signal cabling shall be screened. The screen shall only be terminated to the power earth terminal

Declared as true and correct, for and on behalf of London Electronics Ltd.

J.R.Lees Director