

# London Electronics Limited

Thorncote Road, Near Sandy, Bedfordshire SG19 1PU  
Tel +44(0)1767 626444 Fax +44(0)1767 626446  
www.london-electronics.com help@london-electronics.com

## Panel mounting clock / timer / controller INT2-H

### Connection details, scaling and general information



**Caution:** There is a risk of electrical shock if this instrument is not properly installed



**Caution:** Risk of danger: Read the whole manual before you install this meter



#### The New version of the INTUITIVE Family, with these extra benefits...

- \* 16 bit D/A convertor, greater resolution.
- \* Direct and theoretical linearisation features
- \* More comms options, for faster, more flexible data access.
- \* Extra 'Factor and Offset' feature, allows you to correct for Gravity, Container Tare etc.
- \* Timers on alarm relays.
- \* More alarm setting modes, including in-band and out of band alarms, pump control.
- \* Summary Screen, lets you know which options are fitted, whenever you want to know.
- \* Wider operating temperature range
- \* Variable brightness feature, plus Daylight viewing option for use in direct sunlight
- \* Adjustable menu timeout delay, to suit new and experienced users.
- \* Choice of Basic or Advanced menu in standard model
- \* Outputs selectable from nett or gross.
- \* Real -Time clock option
- \* DIN Rail mounting option

Ordering code: **INT2-H-X-X-X-X-X**

**INT2** = Intuitive Mark 2 family  
**H** = Clock function  
Analogue output: — **0**=none, — **ANB**=-10to+10V, — **ANI**=4-20mA, — **ANV**=0-10V  
Alarm outputs: — **0**=none, — **AL2**= 2 relays, — **AL4**=4 relays  
Serial data: — **0**= none, — **232**=RS232, — **485**=RS485  
Display colour: — **R**=Red, — **G**=Green  
Power: — **AC**=100-240V AC, — **DC**=11-30V DC  
Mounting: — **0** = Standard panel **DIN** = DIN rail mounting

Software version **F00.21**

Document Ref:pm65\manuals\INT2\_H Revision:18 Dated: 3 February 2011

# Warranty

We warrant our products against defects in materials or workmanship for a period of three (3) years from the date of purchase.

In the event of a defect during the warranty period, the unit should be returned, freight (and all duties and taxes) prepaid by the Buyer to the authorised distributor from where the unit was purchased.

The Distributor, at its option, will repair or replace the defective unit. The unit will be returned to the Buyer with freight charges prepaid by the distributor.

## LIMITATION OF WARRANTY

The foregoing warranty shall not apply to defects resulting from:

1. Improper or inadequate maintenance by the buyer.
2. Unauthorised modification or misuse.
3. Operation outside the environmental specification of the product.
4. Mishandling or abuse.

The warranty set forth above is exclusive and no other warranty, whether written or oral is expressed or implied. We specifically disclaim the implied warranties of merchantability and fitness for a particular purpose.

## EXCLUSIVE REMEDIES

The remedies provided herein are the buyer's sole and exclusive remedies.

In no event shall we be liable for direct, indirect, incidental or consequential damages (including loss of profits) whether based on contract, tort or any other legal theory.

# Contents

Warranty	2
Warnings	4
Introduction	5
General Description	6
Panel mounting & Installation - Class II	7
DIN Rail mounting option	8
Other Mounting options	9
Wiring Advice	10
Connections	11
Installation hints for best performance	12-13
Easy/Advanced menu mode	14
Display Brightness	15
Mode Setting	16
Basic clock Configuration	17
Day counter settings	18
RTC setup method	19
Factory defaults	20
Calibration audit number	20
Logic input functions	21
Logic Input connections and front buttons	22
Menu Timeout adjustment	23
Reverse / Mirror display setting	24
Bootup Routine choices	25
Language selection for user interface	26
Error Codes	27
Output Options - installing	28
WEEE	29
Equipment Specifications	30
Record of Revisions	31
Declaration of Conformity	32

## **Separate manuals for options**

Alarm option settings	See Alarm manual *
Analogue output option settings	See Analogue manual *
Serial output option settings	See Serial manual *
Real Time Clock setting	See Serial manual *

\* Need a manual urgently?

You can download manuals from our website.

# Warnings

Please carefully read this manual and all warnings. Install the meter ONLY when you are sure that you've covered all aspects.



Where the product is intended for "UL" installations, removal or addition of option boards is not permitted.



Check that the model number and supply voltage suit your application before you install the meter.



Connect the meter according to current IEE regulations, IEC61010 & NFPA:70 National Electric Code in USA.



This meter is for Installation class II service only. This means it has exposed electrical and power terminals. You must install it in a suitable fire enclosure which will also protect users from electric shock



We designed this meter for Pollution-Degree 2 environments only.



Power supplies to this equipment must have anti-surge (T) fuses rated at 400mA for 230V supply, 400mA for 110V supply or 2A for DC supplies in the range 11-30VDC. Only Siba fuses in series 189500, cULus listed according to file #E167295 are accepted for this service under the terms of UL listing. A switch or circuit breaker, clearly marked as a disconnecting device, must be included close to the installation.



Don't touch any circuitry after you have connected the meter, because there may be lethal voltages on the circuit board.



Only adjust on-board switches or connections with the power turned off



Make sure all screw terminals are tight before you switch the meter on.



Only clean the meter's front with a soft damp cloth. Only lightly dampen with water. Do not use any other solvents. The behind-panel case may be cleaned with a dry cloth only, use no liquid or solvent on it.

**Safety First .....Don't assume anything..... Always double check.  
If in doubt, ask someone who is QUALIFIED to assist you in the subject.**

# Introduction

Please contact us if you need help, if you have a complaint, or if you have suggestions to help us improve our products or services.

If you contact us about a product you already have, please tell us the full model number and serial number, so that we can give you accurate and fast help.

This product has a 2 year warranty. We will put right or replace any meter which is faulty because of bad workmanship or materials. This warranty does not cover damage caused by misuse or accident.

If you return a unit for repair, please include a detailed description of the problem, and the name of a contact who we can refer to for any questions. Please mark for the attention of the QA Department.

## **IMPORTANT**

If this equipment is important to your process, you may want to buy a spare to cover possible failure or accidental damage in the future.

This is because during factory shutdown periods, you may have to wait several weeks for an equivalent replacement, or we may have no stock at the time you urgently need it.

You may also need to pay extra carriage charges if you want a fast, guaranteed courier service. Warranty repairs or replacements are usually returned with a standard courier service.

We do not offer compensation for losses caused by failure of this instrument.

If you do not agree with these conditions, please return this item in unused, condition, in its original packaging and we will refund the purchase price, excluding any carriage paid.

We thought you'd prefer to know about possible delays and extra charges now, rather than during a panic. A spare unit could help to avoid these issues.

We always try to improve our products and services, so these may change over time. You should keep this manual safely, because future manuals, for new designs, may not describe this product accurately.

We believe these instructions are accurate, and that we have competently designed and manufactured the product, but please let us know if you find any errors.

# General Description

This series of meters accepts industrial sensors to allow various physical measurements to be made, such as weight, temperature, pressure, humidity etc. Different models are available for different sensor types.

The main function of this series is to give a numeric readout of the variable being monitored. Most models include an excitation power output, to power the sensor directly.

Various optional output modules are also available to give alarm relay outputs, analogue output or digital communications, or any combination of these options.

Meters are programmed using front panel pushbuttons. The buttons may be locked with a rear switch.

Meters have two power supply options : 100-240 VAC or 11-30VDC

These meters are designed to mount into a protective enclosure which will protect users from contact with power and signal wiring.

These units must be installed fully assembled, and must be installed according to local electrical installation rules. When properly installed, they provide ingress protection to IP65 / NEMA4X from the front

## Safety



**Caution:** There is a risk of electrical shock if this instrument is not properly installed



**Caution:** Risk of danger: Read the whole manual before you install this meter

Obey all safety warnings in this manual, and install the meter according to local wiring and installation regulations. Failure to follow these guidelines may cause damage to the meter, connected equipment, or may be harmful to personnel.

Any moving mechanical device controlled by this equipment must have suitable access guards to prevent injury to personnel if the meter should fail.

# Panel Mounting and Installation - Class II

Install the meters in a suitable protective electrical control enclosure according to local wiring regulations. See specifications for maximum allowable temperature in enclosure. Allow adequate air circulation.

**Installing into front of panel**  
 Remove the two rear bracket screws and safely store them and the U-Bracket for later fitting.

Slide the meter, with gasket into the panel cutout

92mm +1mm -0mm  
 Panel cutout  
 45mm +1mm -0mm  
 Gasket

Bracket screws  
 U-Bracket

**Securing into the panel**  
 Re-fit the U-Bracket and tighten the bracket screws to firmly clamp the meter in place. Check that the gasket is evenly pinched between the meter's front bezel and the enclosure front

**Ventilation**  
 There should be sufficient ventilation in the enclosure to ensure that the meter's case is always kept to less than 60C.

**Meter Spacing.**  
 Meters should be spaced apart sufficiently to allow a free flow of ventilation air around the meters, such that no part of the case will exceed 60C

U-Bracket  
 Bracket screws

**Side view of meter installed in panel**

Bracket screw (1 of 2)

Left side of meter case  
 U-Bracket

Front surface of enclosure  
 Front surface of meter  
 Gasket  
 Front surface of enclosure

## DIN Rail Mounting option

This series is ideal if you need high precision signal conditioning. Sometimes, it is not necessary to have front panel indication, so in such cases, we offer a DIN rail mounting option, which allows the meter to be installed within a control panel.

Detachable connectors add to the simplicity of installation, and of course the setup method is identical to the panel mounting version, so you don't need to learn a new method.

The display remains active, so you can see at a glance the status of your signals, and programming is simple, using the 4 buttons.

Output functions include isolated 16 bit 4-20mA, 0-10V, -10 to +10V, RS232, RS485 and up to 4 alarms with a wide choice of alarm functions.

Install the meters in a suitable protective electrical control enclosure according to local wiring regulations. See specifications for maximum allowable temperature in enclosure. Allow adequate air circulation.

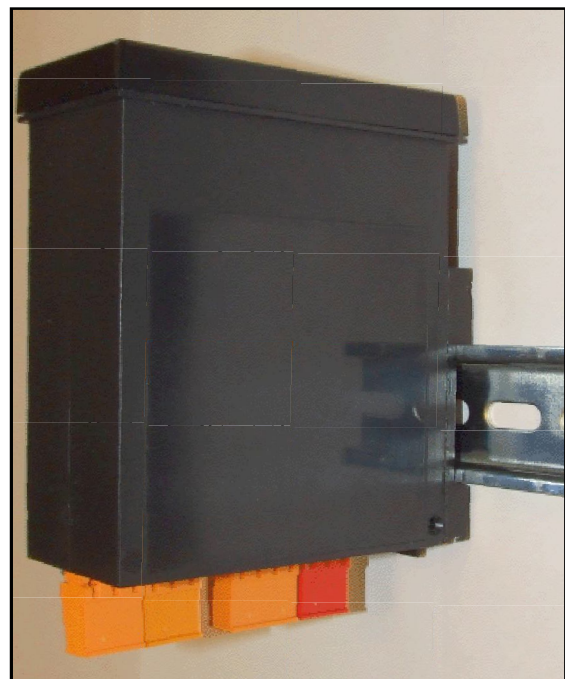

### Securing into the panel

Use standard top-Hat DIN rail 35 mm x 7.5 mm (EN 50022, BS 5584, DIN 46277-3)

### Ventilation

There should be sufficient ventilation in the enclosure to ensure that the meter's case is always kept to less than 60C.

### Meter Spacing.

Meters should be spaced apart sufficiently to allow a free flow of ventilation air around the meters, such that no part of the case will exceed 60C

## Other mounting options

### IP67 SPC4

The SPC4 splashproof cover gives IP67 / NEMA4-X protection for the front of your meter. Ideal for use in harsh wet environments.

Available with optional security tag ports to allow you to fit your own crimped wire tamper-seals, to prevent or indicate unauthorised access (Similar to tags used on electricity meters)

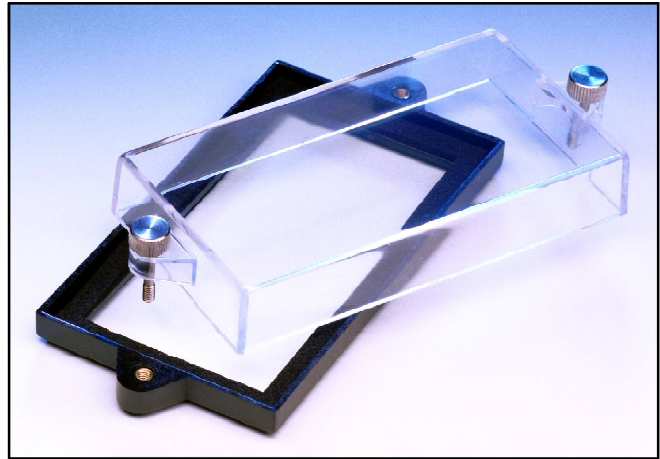

### Wall Box

The Wallbox is sealed IP65 all round, and is supplied with the meter installed, for you to wire to, via 3 cable glands. It comes complete with SPC4 splashproof cover.

We also offer a dual version of this enclosure, which can take 2 meters, one above the other.



### PCC Series

The PCC series of Portable Carrying cases is ideal for housing your panel meters so that they can be used in the lab. These enclosure come fully wired, with panel meters fitted and with IEC switched power connector plus any input or output connectors, as required.

Versions are available to accept 1, 2, 4, 6, 8, 12 or 16 meters



# Wiring Advice

This meter uses detachable screw terminal connectors. Refer to the wiring diagram on the following page for the correct positioning of each wire.

The conductors you use must be suitable for the meter's temperature, current and voltage rating, which is broadly described as follows:-

## Cable Temperature Rating

All cables must be rated for operation up to 90C continuous.

## Cable gauge and screw tightness

The connectors on this instrument can accept conductors up to 16 gauge AWG / 1.5mm<sup>2</sup> c.s.a. The minimum cross sectional area shall be 22 gauge AWG / 0.5mm<sup>2</sup>. Tighten screw terminals to 7.0 lb/in torque / 0.8 Nm torque.

## Cable insulation voltage rating

Cables shall have an insulation voltage rating of at least 380V continuous.

Wire preparation:

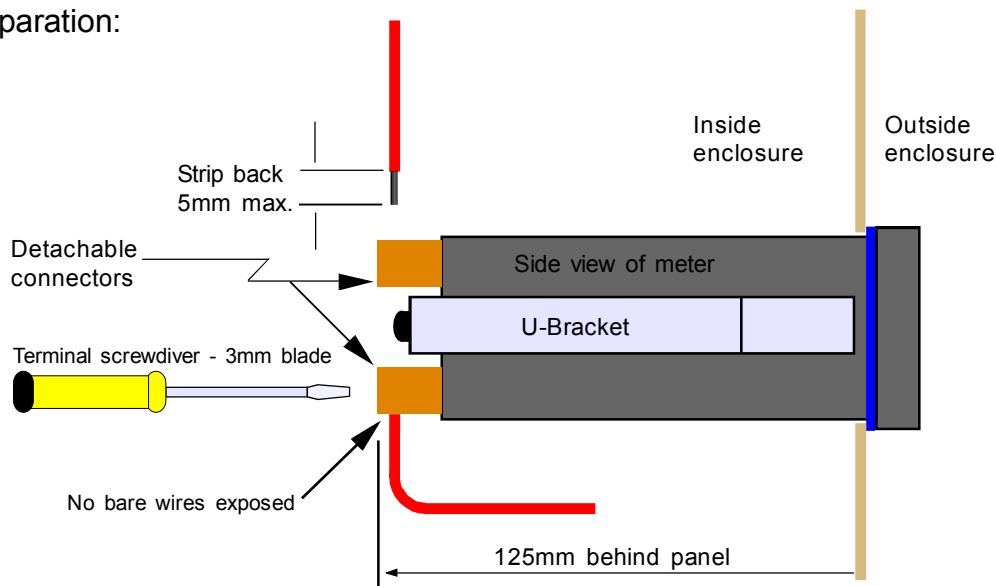

We recommend multi-strand wire, because it withstands vibration better than single strand cable. Pull the wire firmly after you make the connection to confirm it is tight.

Use screened cable for all signal and control wiring and connect the screen to earth at the destination end only. Route signal cabling away from power cabling and relay switching cabling, to avoid electrical noise interference.

# Connections

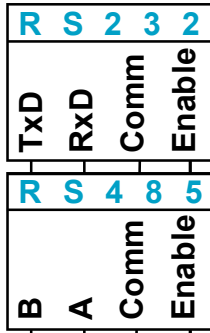

**Enable** is used in mode C1 to activate or de-activate the RS232 or RS485 serial output. Connect to Comm to continually transmit data.

**Connectors and options**  
Connectors may be present even if output options are not installed. Refer to rating label to see installed options.

Rated 2A 250VAC Resistive  
**AL1 AL2 AL3 AL4**

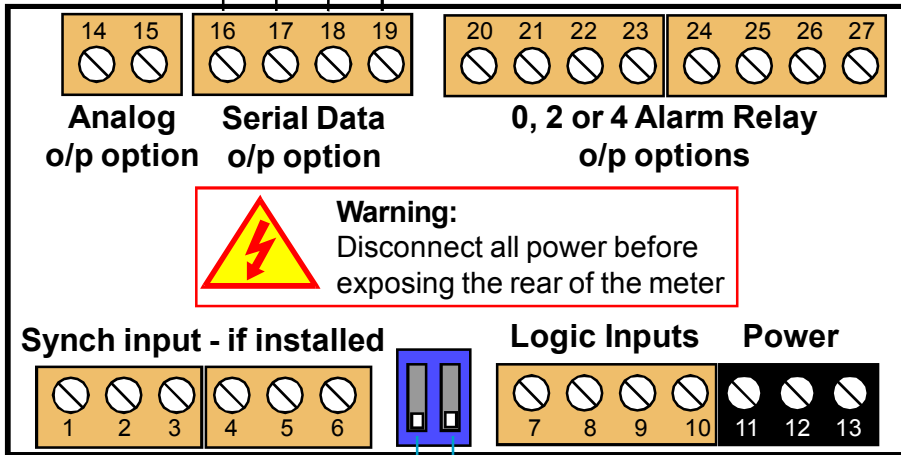

**Class II Installation**

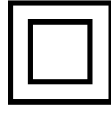

Customer-supplied disconnection and overload protection devices

**Synch input - if installed**

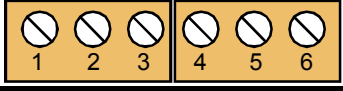

**Logic Inputs**

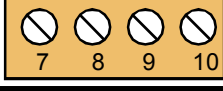

**Power**

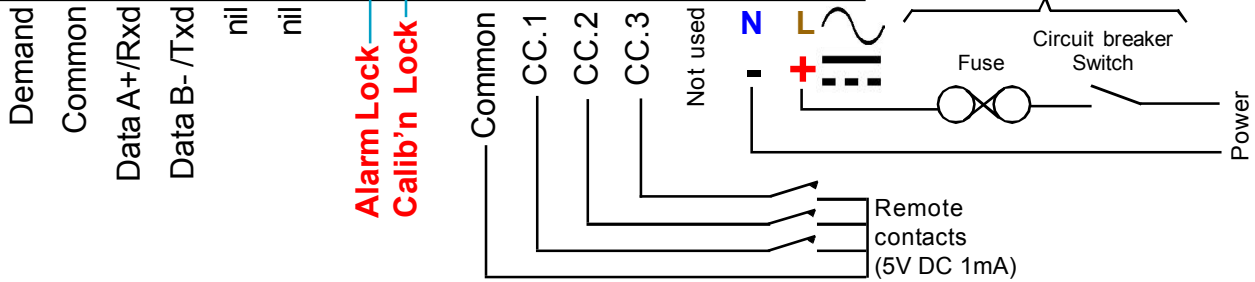

# Installation hints for best performance

This section offers several suggestions which will help you get the best performance from your measurement system.

The logic input signals are comparatively small and can easily be corrupted by the comparatively high level of electrical noise which can be created by electrical machinery such as motors, welding systems, discharge lighting, AC power inverters and solenoids. These steps will ensure you get the best possible performance from your system.

1. Use good quality screened signal cable, with twisted pairs. Belden 8777NH, Belden 9503 and AlphaWire 6010C are good choices, available from many electrical distributors.
2. If you are using multi-pair twisted cable, each pair should be dedicated to a single display as shown opposite, for maximum noise immunity. This will ensure that any electrical noise induced in the cable is properly cancelled. Mixing destinations carelessly amongst the twisted pairs can actually worsen noise performance.
3. The cable should be routed away from noisy wiring and devices such as power feeds from inverters, discharge-lighting cables, welder cabling etc, and should preferably be routed in a dedicated low voltage signalling/instrumentation conduit or cable tray.
4. Screened cable should be earthed at the display end only.
5. All wires and screens coming out of the screened cable should be kept as short as possible to minimise pickup of noise.
6. If you are using barriers, you should earth your screen as shown below, paying particular care that you do not earth both ends of any run of of cable.

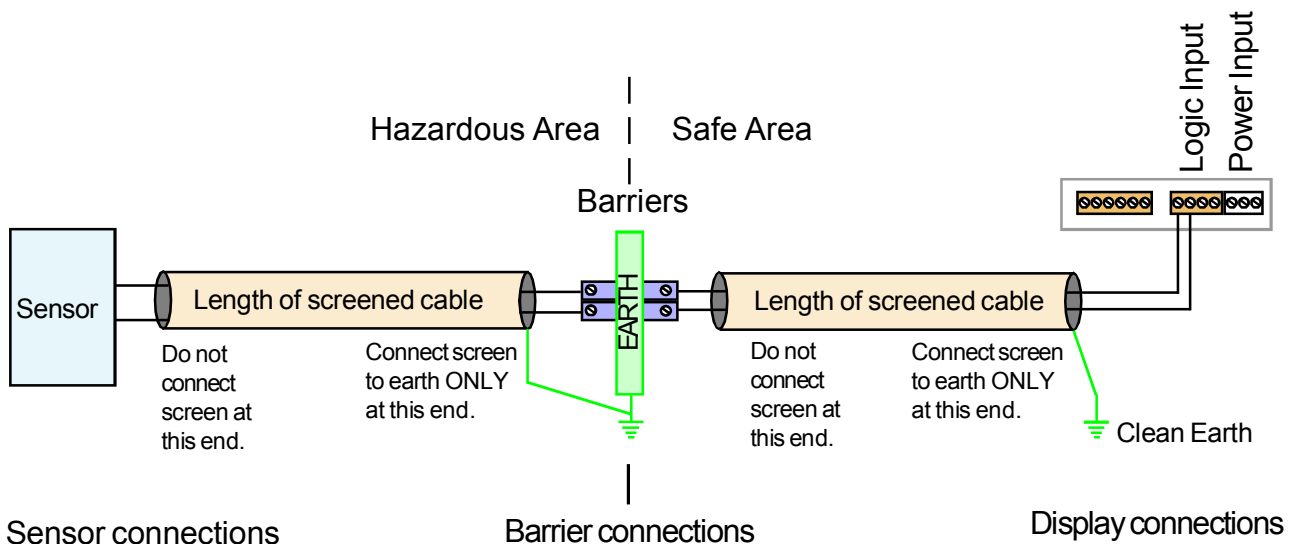

When using multi-core screened cable to connect several displays to several sensors, please be sure to use one twisted pair for each display and sensor.

Do NOT use a wire from one pair for signal positive and a wire from another pair for signal negative, as this will prevent the twisted cables from cancelling any induced electrical noise, and can couple noise from one channel to another.

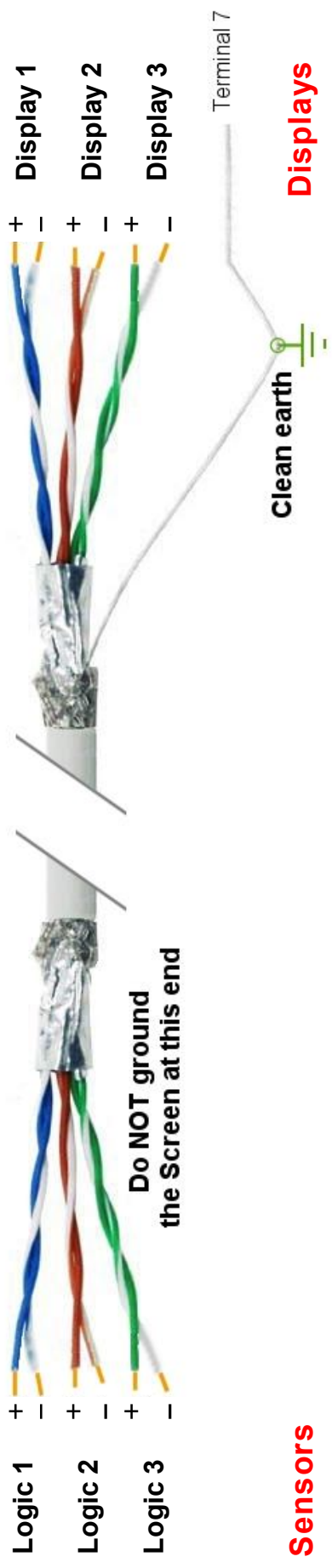

**Sensors**

# Easy or Advanced menu mode

You can choose from two menu modes.

**1. Easy Mode** - This limits the menu to the most commonly required features, in order to make it less complex and easier to navigate. This is the default level.

**2. Advanced Mode** - This gives you access to all available menu features.



Each menu feature in this manual has a heading note to tell you whether it is available in Easy or Advanced mode.

How to choose menu mode:-

**This feature is available in Easy and Advanced Modes**

- Lockout Switch must be OFF   
Circuit board ON

Press together briefly
- Press OK a few times, until you see **Adv.** or **EASY**

Press briefly
- Each press of the DOWN arrow, or UP arrow will alternate between showing **Adv.** or **EASY**

Press to toggle
- Press OK to select your choice.

Press to accept





**Done!**

# Display Brightness

You can adjust the display brightness at any time, provided the display is locked.

**This feature is available in Easy and Advanced Modes**



**1**

Set1 Digit Set2  Output  Alarms  Lockout Switch must be ON  OFF ON

Press 3 seconds





Circuit board

**2**

Set1 Digit Set2  Output  Alarms  Display shows **br ight**  
Each press of the UP button will select a new brightness level. There are 7 brightness levels to choose from. (Default = Full brightness)

Press for 3 seconds

**3**

Set1 Digit Set2  Output  Alarms   Done!

Press to accept





Did you know, we make this display in two brightness versions? Standard brightness for use inside, and Daylight Viewing for use outside in direct sunlight. The Daylight Viewing version has suffix -DLV in its part number.

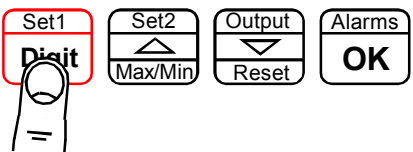

# Mode Setting

The display's calendar and internal clock will need to be set whenever the battery is renewed, and the clock may need to be set from time to time, if it is not synchronised to a master timesource, such as our ASR-GPS

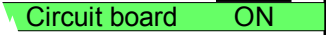
**This feature is available in Easy and Advanced Modes**

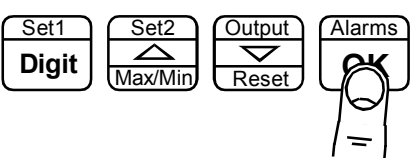
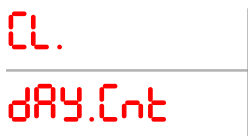
**1** —  **Lockout Switch must be OFF**   
Press together for 3 seconds 

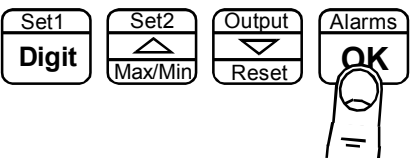
**2** —  **Display shows the available modes**  
  
Clock Mode  
Day counter mode (eg days since last accident)

**3** —  **Done!**  
Press to accept 

# Basic clock configuration

If the display is being used in clock mode, the following basic configurations will be available ....

**This feature is available in Easy and Advanced Modes**

**1**

Press 3 seconds

**Lockout Switch must be OFF**

Circuit board ON

**2**

Press to scroll through the available mode choices and press OK to select.

Display shows input channel choices...

Display format...

24Hr  
12Hr

Daylight saving time modes...

dSt    OFF    US    EU  
         None    USA    Europe

Display sequencing dwell times...

C 00.0 Clock visibility time (seconds)  
t 00.0 Temperature visibility time (seconds)  
H 00.0 Humidity visibility time (seconds)

NB. All three are normally set to 0.00 and are only altered if you connect a remote ASR-GPS master clock to the display, with Temperature and Humidity sensors installed.

**3**

Press to accept

**Done!**

See the following page if you chose Day Counter mode...

# Day Counter settings

If the display is being used in Day Counter mode, the following basic configurations will be available .....

**This feature is available in Easy and Advanced Modes**

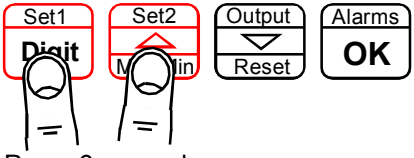
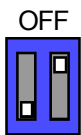
**1** —  **Lockout Switch must be OFF**   
Press 3 seconds **Circuit board ON**

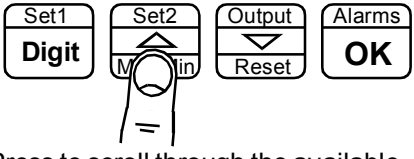
**2** —  **Display shows input channel choices...**  
Press to scroll through the available mode choices and press OK to select.

**Counting direction...**  
**UP** Up counting, normally from zero  
**dn** Down counting, normally from preset

**Offset adjustments**  
**Pr.ESEt**  
Display goes to this value whenever it is reset, and the display will normally count down from this value to 0  
**Pr.LoAd**  
If a period has already elapsed, when the display is installed (For example you are installing the display to show Days since last Accident and so far there have been 349 days without accident, you would set Pr.Load to 349) you can enter this value here. When the display is reset, the display will go to 0

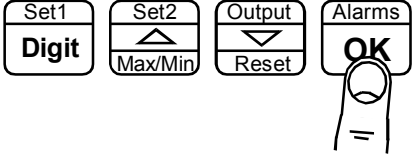
**3** —  **Done!**  
Press to accept





See the previous page if you chose Clock mode...

# RTC setup method

The display's calendar and internal clock will need to be set whenever the battery is renewed, and the clock may need to be set from time to time, if it is not synchronised to a master timesource, such as our ASR-GPS

This feature is available in Easy and Advanced Modes

1





**Lockout Switch must be OFF**



Circuit board ON

Press together for 3 seconds

2











Display shows each of the parameters and you can move on to the next one with the OK button.

Edit settings with the DIGIT, UP and DOWN buttons, OK to accept. Let us assume it is March 24, 2011. If the time will soon be 14:59 you will set ...

yr. 11	Set the last 2 digits of the year
m. 03	Set the month. 1=Jan, 12 = Dec
dt. 24	Set the date 1=1st , 31=31st
14:59	Set the hour
14:59	Set the minutes
14:59 	The time will brighten and the 4 leds to the right of the display will flash. At exactly 14:59, press the OK button. No menu timeout.

3



Press to accept



**Done!**

19

# Factory Defaults

You can return the display to its factory default conditions whenever you wish. If you do so, you will permanently lose all your settings and will need to start from the beginning again.

The calibration Audit Counter will NOT be reset, there is no way provided to reset this value, as it is intended as a secure record to indicate whether changes have been made to the display since it was last calibrated..

**This feature is available in Easy and Advanced Modes**

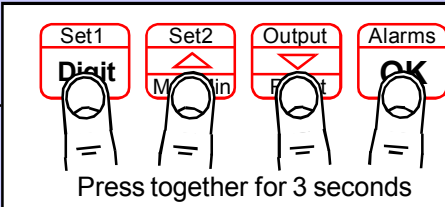
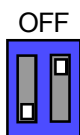
**1** —  **Lockout Switch must be OFF**  **Circuit board ON**

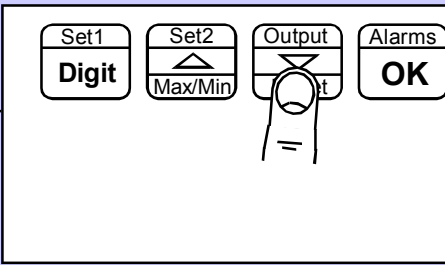
**2** —  **Display shows :-**  
**dEFS n** (Defaults no)  
 Press the DOWN button to change the display to **dEFS y** (Defaults Yes) if you want to return to default conditions.

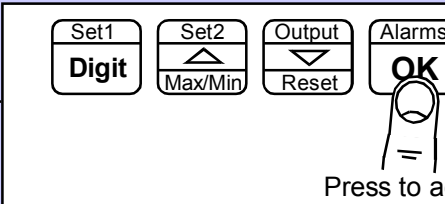
**3** —  **Done!**  
 Press to accept

# Calibration audit number

Your display includes a non-resettable counter which increments each time you make a change to the display's calibration. This is useful if you want to check whether a display has been altered since it was last calibrated.

The Calibration audit number starts at **CAL 01** up to **CAL FF** allowing up to 255 alterations to be recorded. Whenever you want to check the calibration audit number, press and hold the 2 outer buttons (Set1 + Alarms) for more than 3 seconds.

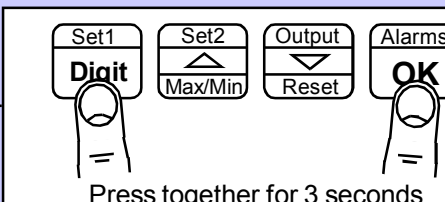
**1** —  **Done!**

# Logic input functions

The three contact closure inputs on the rear of the meter have default functions which are:-

- Contact closure 1 = Tare
- Contact closure 2 = Peak/Valley display
- Contact closure 3 = Reset

You can re-assign these to include :HOLD, Nett/Gross value display, Memory page address 1,2 or 4 (only if Multi-memory MEM option is installed)

!! This feature is available in Advanced Mode only !!

1

Set1  
Digit

Set2  
Max/Min

Output  
Reset

Alarms  
OK

**Lockout Switch must be OFF**

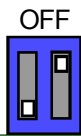



Press 3 seconds

Circuit board **ON**

2

Set1  
Digit

Set2  
Max/Min

Output  
Reset

Alarms  
OK



Press repeatedly until you see **CC. 1**, followed by the existing function for Contact Closure 1.

After you have set **CC. 1**, you will get the prompt **CC.2** to allow you to set Contact Closure 2 function and when you have set CC.2 you will get the prompt **CC.3** to allow you to set Contact Closure 3 function

3

Set1  
Digit

Set2  
Max/Min

Output  
Reset

Alarms  
OK

Use UP or DOWN buttons to select from these available functions...

<p>Defaults are:-</p> <p><b>CC. 1</b> = TARE</p> <p><b>CC. 2</b> = PU</p> <p><b>CC. 3</b> = rSt</p>	<p><b>TARE</b> = Tare display to 0</p> <p><b>PU</b> = Peak/Valley toggle</p> <p><b>rSt</b> = Reset</p> <p><b>HoLd</b> = Freeze display</p> <p><b>Nett.Gro</b> = Nett / Gross display</p> <p><b>PA. 1</b> = Page Address 1*</p> <p><b>PA. 2</b> = Page Address 2*</p> <p><b>PA. 4</b> = Page Address 4*</p>
---	--

4

Set1  
Digit

Set2  
Max/Min

Output  
Reset

Alarms  
OK



Press to accept



**Done!**

\* Only available if the Multi-memory MEM option is installed

21

# Logic input connections and front buttons

The previous page explained how to select the functions of the 3 logic inputs. You can connect remote contact closures or open NPN collectors to activate these logic inputs.

The logic input provides a 5V DC signal. When you connect this to common, a current of 1mA will flow. Because this is a small signal, we recommend you use switches with gold plated contacts, or self cleaning contacts, for best long term reliability.

The logic inputs are not galvanically isolated from the input signal.

The logic inputs are only activated when the lockout switch is ON

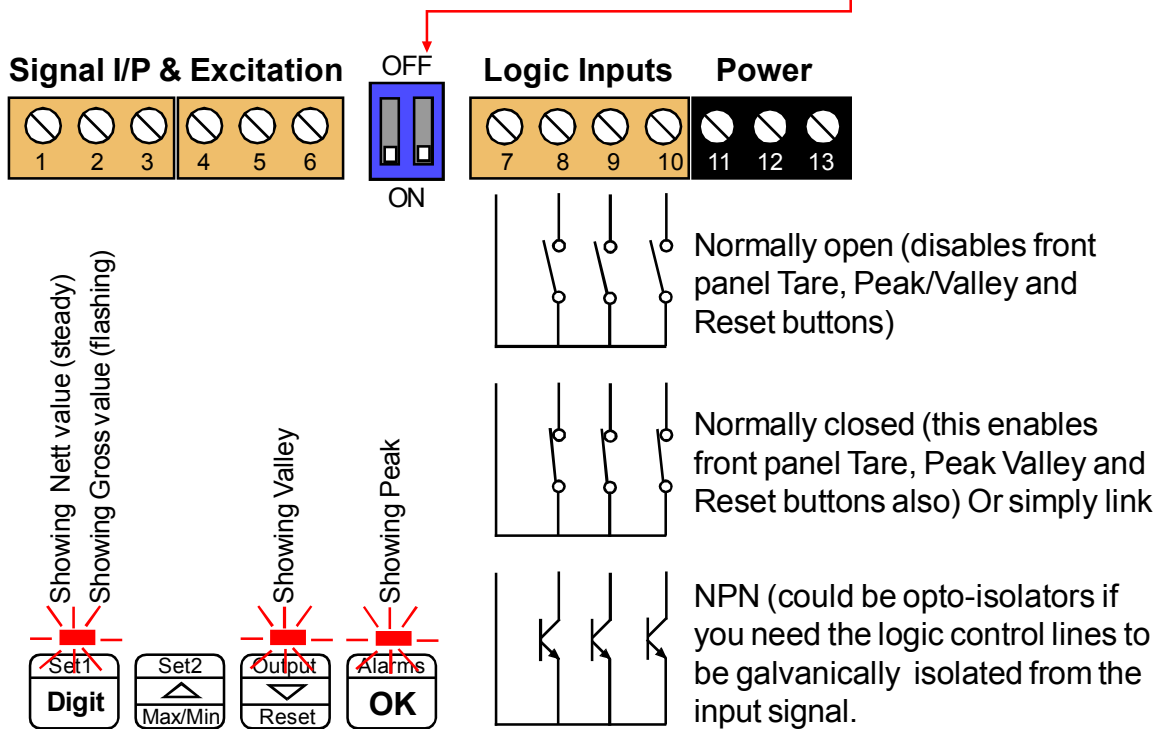

**TARE** = Tares display to 0. Often used in weighing systems to zero a display prior to making a measurement. Net weight is shown once tared. When a display has been tared the small LED above the Set1 button will be illuminated.

**PU** = Peak/Valley toggle. Allows you to view the maximum and minimum values which have been displayed since last reset. 0% LED illuminates when showing valley, 100% LED illuminates when showing peak.

**rst** = Reset. This clears any tare, peak, valley, alarm latch

**Hold** = Freezes the displayed value for as long as the Hold input is closed

**net.gro** = Allows you to toggle between Nett and Gross values on the display

**PA. 1 .. 4** = Page Addresses, if MEM option is installed.

# Menu timeout adjustment

The display has a default timeout of 60 seconds, to allow you sufficient time to refer to the manual between key operations.

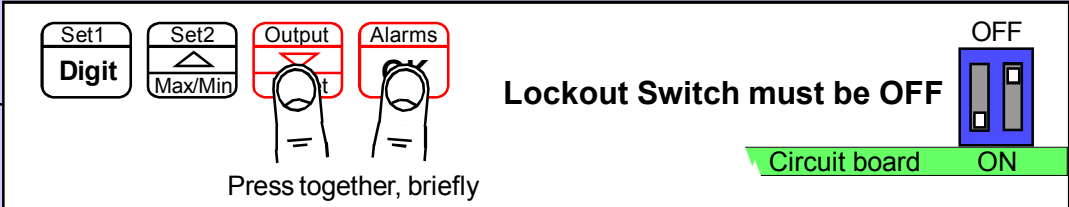

You can make this period shorter, if you wish, once you become more familiar with the setup method.

**!! This feature is available in Advanced Mode only !!**

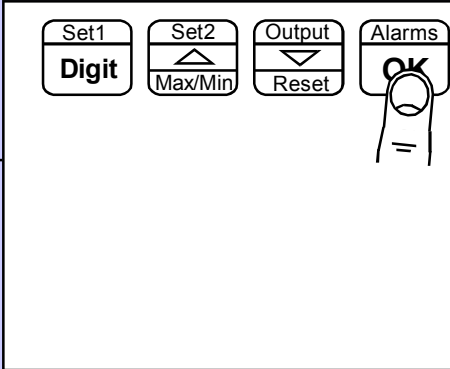
**1** —  **Lockout Switch must be OFF**  
Press together, briefly

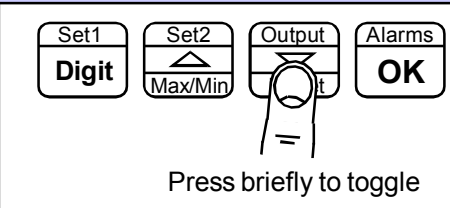
**2** —  Press repeatedly until you see **dLAY. XX** where **XX** is the delay in seconds. Choices are ...  
**dLAY. 10**  
**dLAY. 20**  
**dLAY. 30**  
**dLAY. 60** (default)

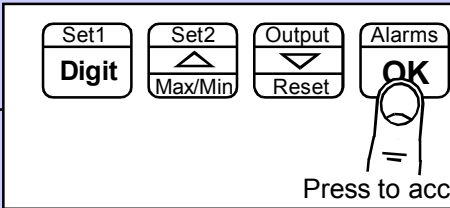
**3** —  Press DOWN or UP button briefly and repeatedly to choose from  
**dLAY. 10** or **dLAY.20** or **dLAY.30**  
or **dLAY.60**  
Press briefly to toggle

**4** —  Press to accept  **Done!**

# Reverse Display function (mirror image)

If you need to be able to see a reflection of the display in a mirror or other reflective surface, for example in a simple heads-up system, or for drivers reversing into a bay, using mirrors only, you can set the display to show as a mirror image.

**!! This feature is available in Advanced Mode only !!**

- Lockout Switch must be OFF

Circuit board ON

Press together, briefly
- Press OK button briefly and repeatedly until you see

rEU.d 0 (Default)  
or  
rEU.d 1
- Press DOWN or UP button briefly and repeatedly to choose from

rEU.d 0 (normal display) or  
rEU.d 1 (mirror image display)

Press briefly to toggle
- Press to accept

Done!



Example of normal display format displaying the number 876543



Example of Mirror Reverse display format displaying the number 876543

# Bootup routine choices

When you switch on your meter, it can be set to power up with 3 possible summary message combinations.

The choices are:-

- boot 0** = Segment test, followed by a full summary of software revision, calibration audit number, model number, installed options.
- boot 1** = Segment test followed by model number (Default)
- boot 2** = No summary, meter displays the measurement value immediately power is applied.
- boot 3** = Segment test which remains active until a button is pressed.

**!! This feature is available in Advanced Mode only !!**

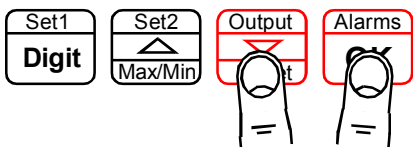
- 

Press together, briefly

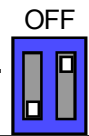
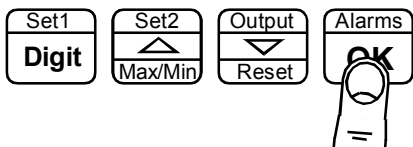
**Lockout Switch must be OFF**  
  
Circuit board ON
- 

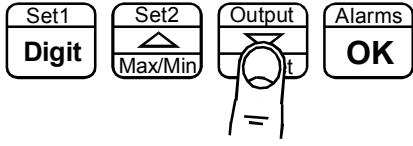
Press OK button briefly and repeatedly until you see **boot 0** or **boot 1** or **boot 2** or **boot 3** displayed.
- 

Press briefly to toggle

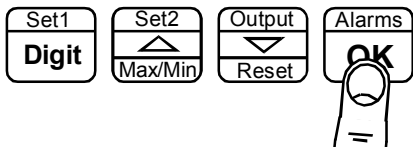
Press DOWN or UP button briefly and repeatedly to choose from **boot 0** or **boot 1** or **boot 2** or **boot 3**
- 

Press to accept

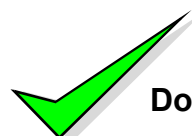
  
**Done!**



You can trigger the full summary message whenever you want, without having to power the meter off, by pressing and holding the 2 outer buttons (Set1 + Alarms) for more than 3 seconds.

# Language Selection for user interface

You can select English or French menu prompts.

**This feature is available in Easy and Advanced Modes**

**1**

Set1 Digit    Set2 Max/Min    Output    Alarms    Lockout Switch must be OFF    OFF

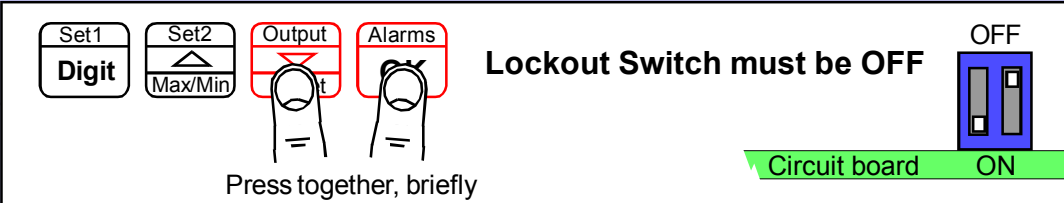

Press together, briefly

Circuit board ON

**2**

Set1 Digit    Set2 Max/Min    Output    Alarms OK

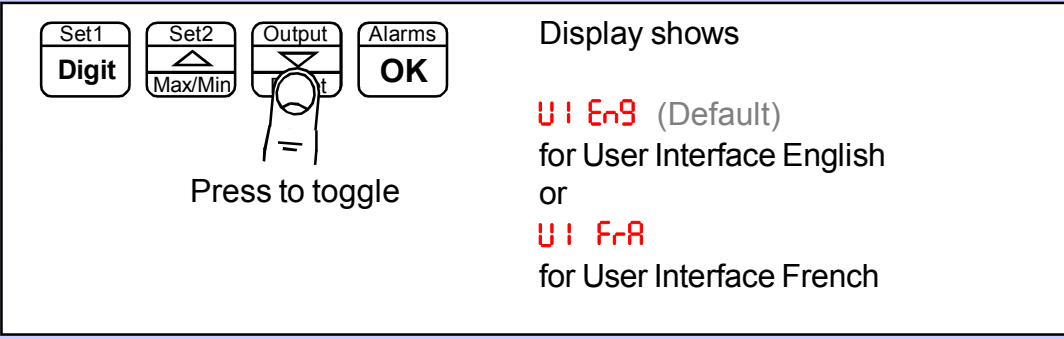

Press to toggle

Display shows  
UI En9 (Default)  
for User Interface English  
or  
UI FrA  
for User Interface French

**3**

Set1 Digit    Set2 Max/Min    Output Reset    Alarms OK

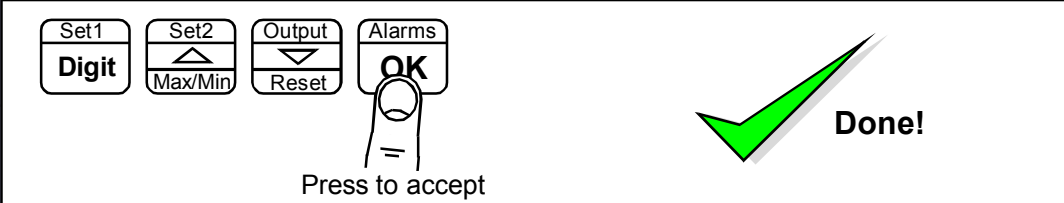

Press to accept

Done!

# Error codes and fault finding



1. Under Range. The meter is being asked to display a value which is more negative than its limit of -199999



2. Over Range. The meter is being asked to display a value which is higher than its limit of 999999

These fault codes could be displayed because the signal scale factor has been set too large or because the input frequency is too high.

3. Display is reading much higher than you expect and may also be erratic. This could be caused by contact bounce if you are using a contact closure input - be sure that the contact debounce is enabled **dbnc.on**

4. Total is not saved on power-down in a DC powered totaliser.

This could be caused by converting a DC powered INT2-P, INT2-L, INT2-S etc to an INT2-C. If you have converted one of these models to INT2-C, simply by changing the input board, you will find that total is not stored at power-down. You will need to fit a power-down control module, part number 9122-0401 to the display control board.

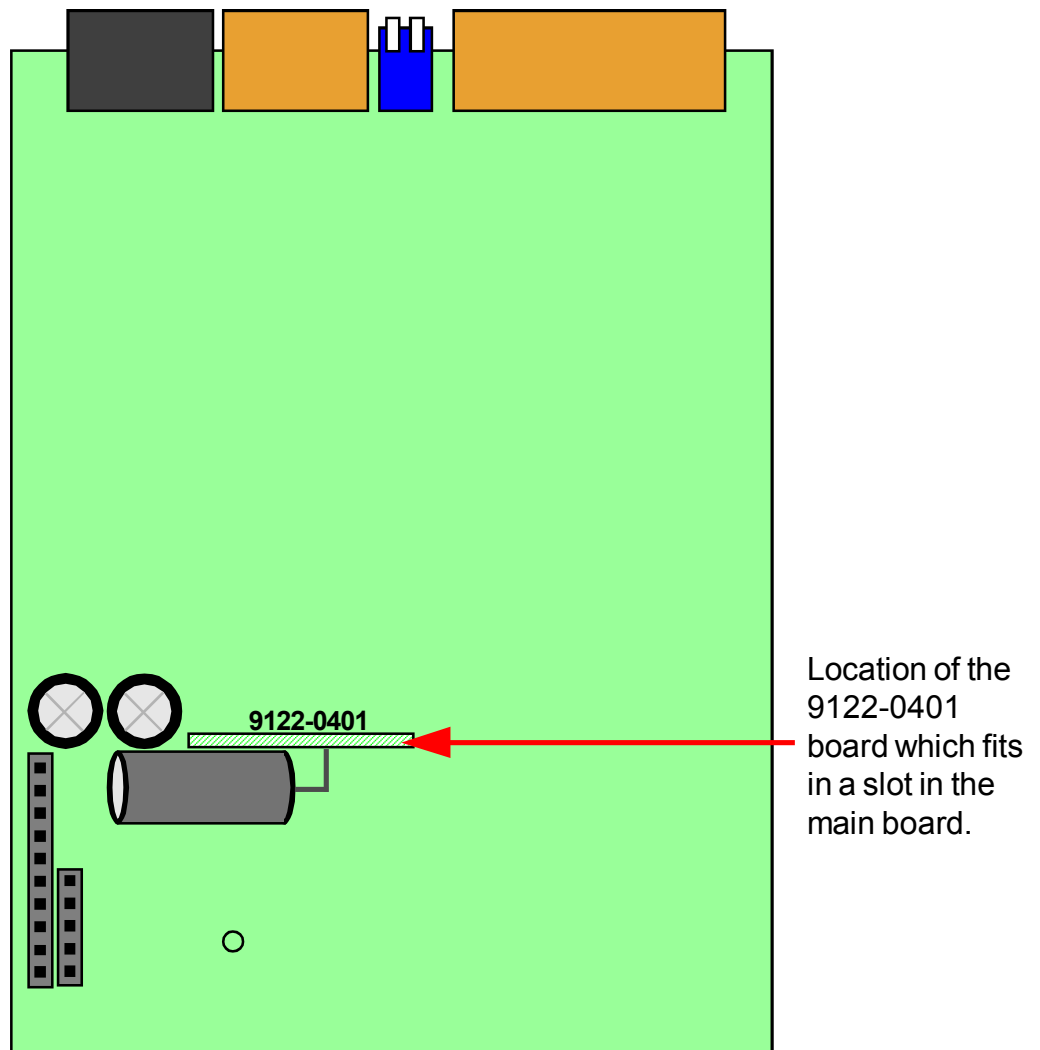

# How to install option boards



Where the product is intended for "UL" installations removal or addition of option boards is not permitted.



**Warning:** Disconnect power before you expose the rear of the meter

If you want to open your meter to install or modify option boards, follow these steps...

- 1) Switch off power to the meter and unplug all connectors.
- 2) Unclip the front bezel. This is easier if you squeeze the top and bottom of the case, near the front.
- 3) Remove the small screws shown in the diagram. If the meter doesn't yet have an output option board, the top screw may not yet be fitted.
- 4) Slide the electronic boards out through the front of the case. You can easily separate the upper option board from the main board. We strongly suggest that you use anti-static precautions to prevent damage to the semiconductors.

The board assemblies will look something like this...

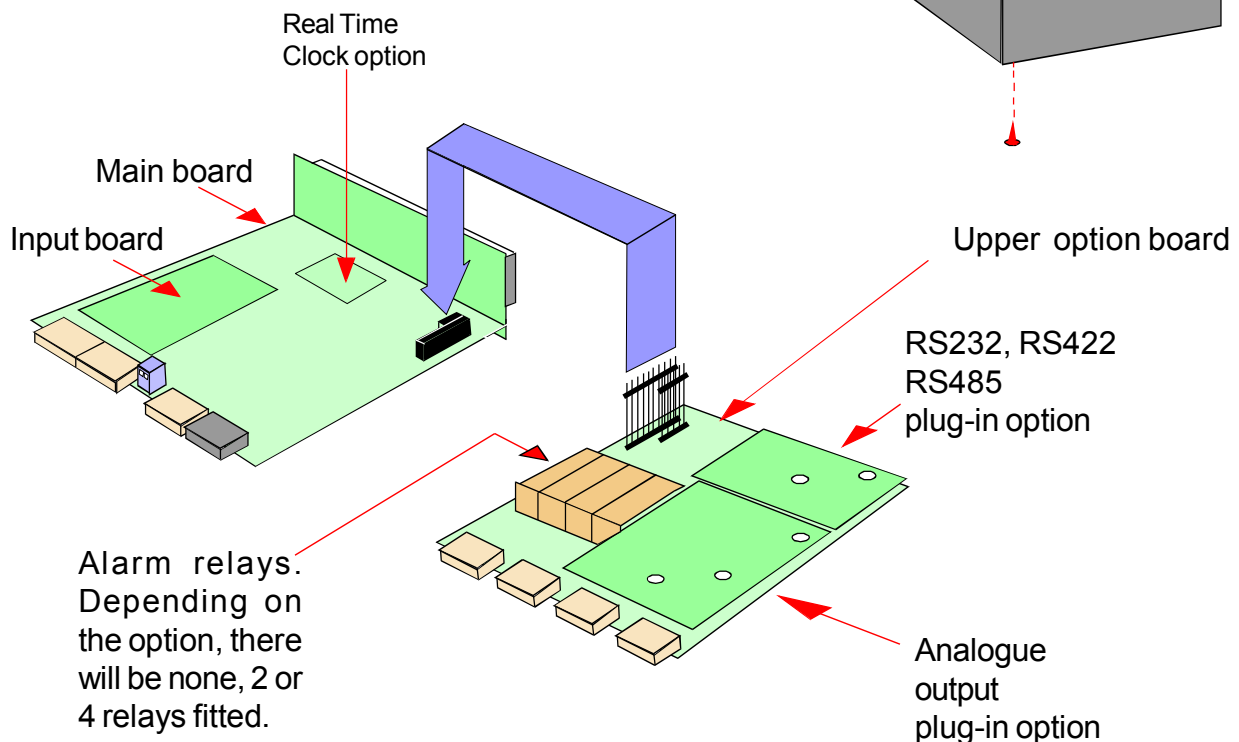

The analogue output and RS232 or RS422 plug-in option boards are fixed to the upper option board with white plastic pillars. You must apply a firm force when fitting or removing these options.

Always be careful to connect the pins to sockets accurately. When reassembling, make sure option boards are firmly fixed to the upper option board. When the boards are replaced in the case, secure them again with the two small black screws.

# Waste Electrical Electronic Equipment (WEEE)

In Europe, this equipment must be disposed of in accordance with European Parliamentary Directive 2002/96/EC

This directive encourages recycling and the reduction of waste materials in the environment.

This means it must be sent to an approved recycling plant if you want to dispose of it.

It must not be thrown away with general rubbish.



# WEEE Waste Recycling

If you are unable to dispose of this item locally, you may send it to us for recycling.

## Conditions:

1. We will only accept items of our manufacture.
2. You must pay for the transport of the goods to us.
3. We will only accept items if they include a signed declaration by an authorised person in your organisation, stating that :-
  - i. The item is safe to handle and has no contaminants which may be harmful to health.
  - ii. You wish us to dispose of or destroy the item(s)

## Equipment Specifications

<b>Bezel size</b>	48mm high by 96 mm wide (1/8 DIN)
<b>Panel Cutout</b>	45 mm high by 92 mm wide
<b>Case Depth</b>	125 mm including connectors
<b>Weight</b>	300 grammes
<b>Case Material</b>	Black polycarbonate
<b>Connectors</b>	Detachable Screw Terminal connectors
<b>Environmental</b>	Storage Temperature range -20 to +70C, non condensing Operating temperature range 0 to 50C, non condensing. Allow 30 minutes for display to reach thermal equilibrium Front sealed IP65. Optional cover SPC4 for IP67
<b>Power Burden</b>	100-240 VAC, 45 to 60Hz or 11-30 VDC optional 10VA maximum
<b>Accuracy</b>	Accuracy better than +/- 10 seconds per month (DS3231SN) Battery backup during power loss. Battery = CR1620 3V Lithium
<b>Memory</b>	Settings saved in 10 year non-volatile memory.
<b>Display Range (max)</b>	888888 or 88:88:88 format

### Plug-In Output Options

<b>Analogue O/P</b>	See analogue output manual for details.
<b>Alarm Relay O/P</b>	See alarm output manual for details.
<b>ASCII Data O/P</b>	See Serial communications output manual for details.
<b>Calendar/Clock option</b>	See serial output manual for details.

# Record of Revisions

- |                  |   |
|------------------|---|
| 6 September 2010 | Version F0.18 Software released. Manual format revised to improve clarity and segregate easy from advanced menu functions. Optional outputs now described in their own dedicated manuals. DIN Rail mounting option added. Cabling guidance added. |
| 3 February 2011  | Version F00.21 Software released. New bootup routine added, increased warranty to 3 years and changed conditions.   |

# Declaration of CE Conformity

Declaration Reference : INTUITIVE Mk2  
Issue Date : 30 April 2007  
Products Covered : INTUITIVE Mk2 series  
Title : DOC-INTUITIVE2

This is to confirm that the Product covered by this declaration has been designed and manufactured to meet the limits of the following EMC Standard :

**EN61326-1:1997**

and has been designed to meet the applicable sections of the following safety standards

**EN61010-1:2001**



## Conditions

The meters are permitted a worst case error of 1% of A/D range during electro-magnetic disturbance, and must recover automatically when disturbance ceases without the need for human intervention, such as resetting, power-down etc.

The meters covered by this certificate must be installed in adherence to the following conditions :-

Signal cabling shall be routed separately to power carrying cabling (includes relay output wiring)

All signal cabling shall be screened. The screen shall only be terminated to the power earth terminal at the meter end of the cable.

Declared as true and correct, for and on behalf of London Electronics Ltd.

J.R.Lees Director